

man, technology and nature

WORLDWIDE ITALIAN TALENT

When TECOMEK was established in 1987, a new production and commercial company made its debut on the world market for forestry and gardening machinery. About fifteen years later the company has consolidated its success, by distribution of more than 10.000 articles in 50 countries. The secret of this success lies in the company 's philosophy, in the common spirit that moves all ist staff and its production and commercial organization – a winning and innovative spirit. Tecomec combines a remarkable operating versatility with the typically Italian business creativity. Thanks to his rare ability to understand and foresee the market needs, Tecomec punctually renews its production lines to offer always latest-concept products. The company operates to the severest quality standards; its products are certified according to safety standards in force both in European Union and in the major extra EU countries. Since some years TECOMEK is a member of YAMA group which embraces more than 20 companies operating on parallel markets. Together they are the major Italian pole in the production of gardening and forestry machinery.

ACCESSORIES THAT ALWAYS MAKE A "SHARP" DIFFERENCE

The complete range of electric saw chain grinders is Tecomec's major series. As a matter of fact, "Jolly" has become the name of the electric grinding machine across the world. Thanks to its success, several models with different technical characteristics have been developed to satisfy all users requirements.

However, electric grinders are only a part of a larger line of accessories for saw chain repair and maintenance, thanks to which Tecomec gained a worldwide leadership on the market.

index

Chain saw accessories

2-33

Brushcutters accessories

34-85

Chain saw spare parts

88-107

chain saw accessories



JOLLY Star	4
Super JOLLY	6
Midi JOLLY	8
Baby JOLLY	9
Grinding Wheels	10
Accessories For	11
Chain Grinders	11
Accessories For	12
Chain Grinders	12
De LUXE	13
Super RAPID	13
Filing Vise	14
Magnetic Filing Angle Guide	14
Dept Gauge Jointers	15
Bar Groove Cleaner	15
File Handles	15
Flat File Holders	16
Chain Sawfiles	16
Push Rod	16
Flat File Holders	17
Filing Kit	17
Steel	19
Chain Breaker	19
Nudular Cast Iron Chain Breaker	20
Adjustable Anvil	21
Socket Anvil For Oregon® Chains	21
3/4" Bush Chain Anvil	21
Wedges	22
Pocket Chain Breaker	22
Steel Rivet Spinner	23
Nudular Cast Iron Rivet Spinner	24
Take-up Handles	25
Spinner Inserts	25
Rivet MASTER	26
Piston Stop	27
Piston Ring Clam Set	27
Pressure Gauge	28
Pressure Gauge Kit	28
Grease Guns	29
Bar Guards	29
Wedges	30
Lawnmower Blade Balancer	31

PROMIS.

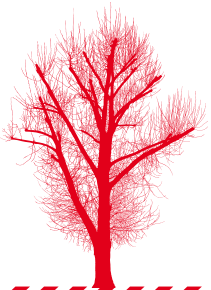



**chain
saw
accessories**

Forestry and gardening accessories



LEGENDA



Particularly suitable for professional saw chain maintenance technicians.



Range of chains on which it can be used.



Usefull for "Down Angle" sharpening chain.

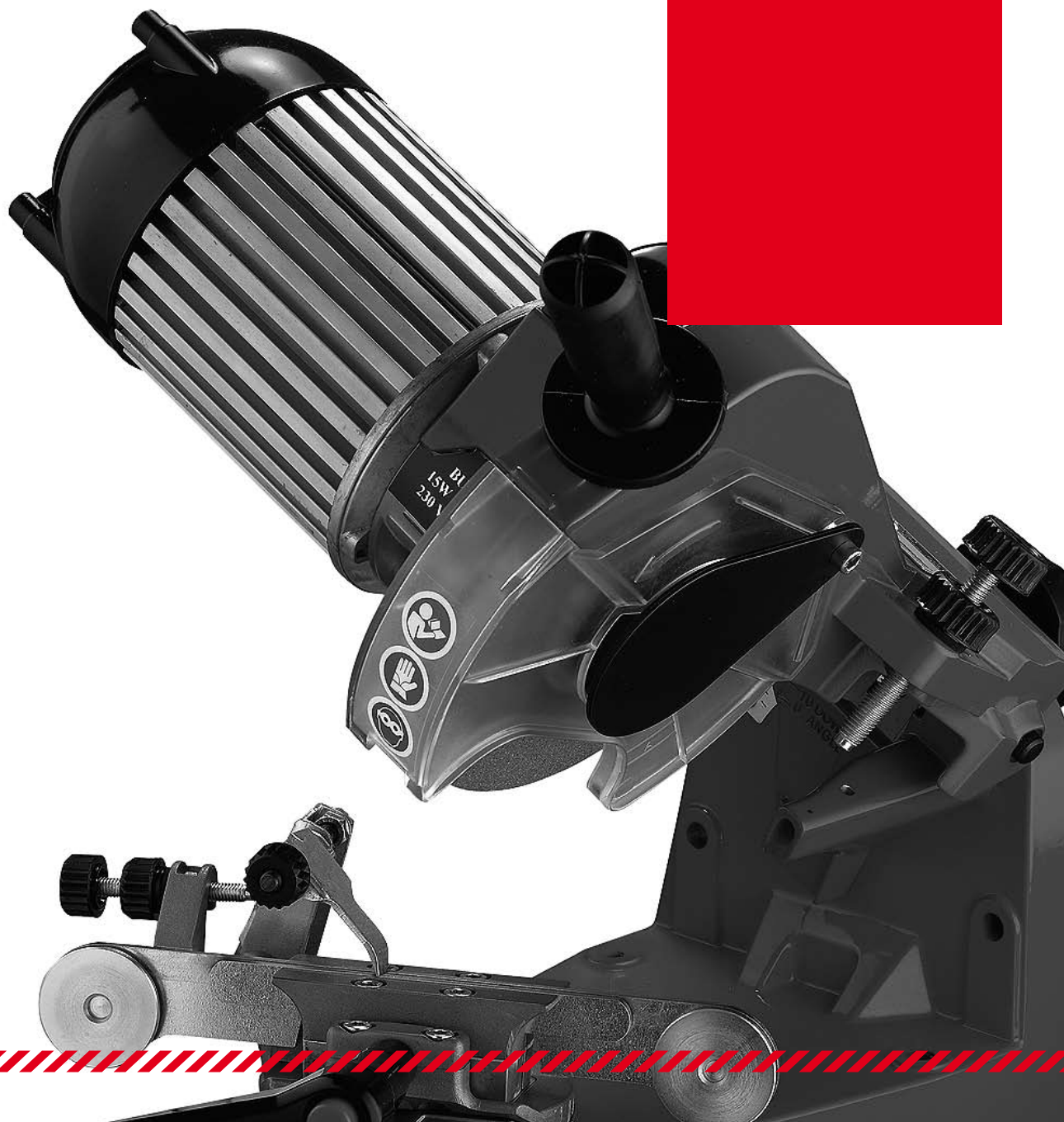

HIGHT PERFORMANCE

JOLLYStar

chain grinder

NEW



New concept bench chain grinder designed for perfect matching the original chain cutting angles.
EASY AND RELIABLE:

- Self-centering chain vise: Equal and consistent grinding angles without additional adjustments
- Clear and evident setting steps since based on saw chain geometry
- Correct position of grinder's head pivot axis on the chain on all positions

Most reliable sharpening of all sizes of saw chains: from 1/4" to 3/4" pitch.

BEST GRIND AND CHAIN PERFORMANCE ENSURED!

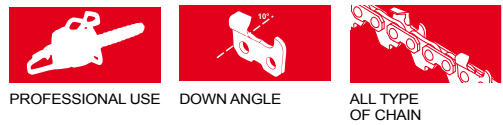

P/N	VOLTAGE	RATED POWER	MAX SPEED	WEIGHT	CHAIN PITCH
11359001	230 V~ 50 Hz	214 W	2800 min ⁻¹	6 kg	1/4" ÷ 3/4"
11369001	120 V~ 60 Hz	300 W	3400 min ⁻¹		

Generative EAN13 code available.

PACKAGING

CARTON

ORDER MULTIPLES OF

4 PCS

CERTIFICATIONS

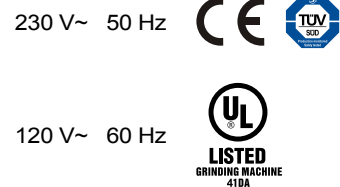

PROVIDED WITH FOLLOWING ITEMS

GRINDING WHEEL

1 pc. Thickness 3,2 mm for: 1/4" - .325" - 3/8" chains
 1 pc. Thickness 4,7 mm for: .325" - 3/8" - .404" chains
 1 pc. Thickness 6,0 mm for depth gauge

DRESSING BRICK

1 pc.

TEMPLATE

1 pc.

WRENCHES

1 pc. HEX. 4 mm
 1 pc. HEX. 5 mm



highlights

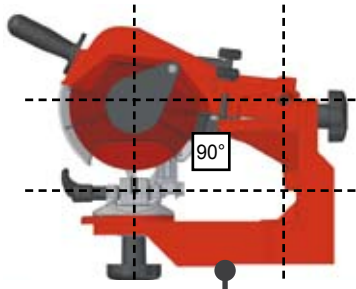

GRINDING HEAD PIVOT AXIS

The pivot axis of the head and vice have been repositioned for a better geometric solution ensuring a right/left hand grind equality.

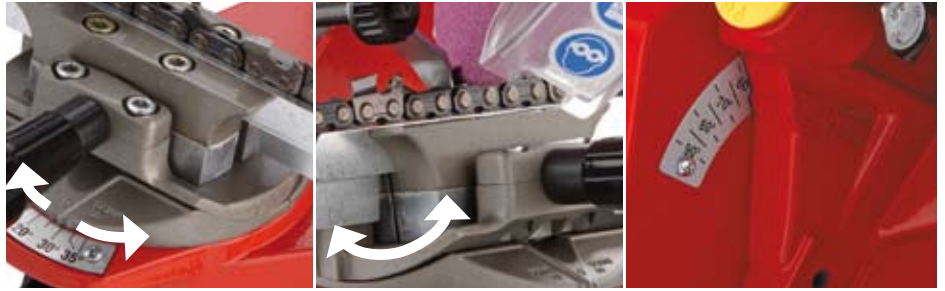

DOWN ANGLE COMPENSATION ADJUSTMENT

When a down angle is required, the vice can be rotated forward or backward 10° in its base to set the down angle for left or right hand cutters.

When the vice is set to give a 10° down angle, compensation must be made on the top plate cutting and filing angles. Additional pointers are provided to make these compensations. When adjusting the top-plate filing angle, use the left pointer for left-hand cutters and the right pointer for right-hand cutters. Optimum grind geometry.



SELF-CENTERING CHAIN VICE

Equal grind angles without adjustment. The new self-centering vice ensures the correct & perfect relation between the chain axis and the vice rotation axis for all types of chain from 1/4" pitch to 3/4" pitch. When actioning the vice adjustment knob, both vice jaws close on the chain. This ensures the chain is ideally positioned at all times for optimum grind geometry & equal grind angles.



ADJUSTABLE VISE HANDLE

By pushing the button in the center of the vise handle, the handle can be disengaged and rotated to the position that is most convenient for the operation of the grinder. Increased visibility and ease of operation.



WHEEL DRESSING POSITION

This new feature allows the wheel to be dressed in a convenient and safe "head-up" position..



TORSION SPRING - THE "LIGHT TOUCH"

The new spring design contributes to a much smoother control of the grinding operation and requires no effort from the user. It gives the operator an excellent feeling when grinding.



SWITCH

This type of switch is disabled automatically in the case of a power supply failure.



LIGHT

The light is fitted next to the chain grinder and illuminates the whole work area perfectly.

accessories



GRINDING WHEEL Th. 8 mm (FOR 3/4" PITCH CHAIN) P/N 01005000



3/4" GAUGE TEMPLATE P/N D00400000

SUPERJOLLY

chain grinder

Powerful and professional chain grinder. An exclusive hydraulic system ensures automatic chain locking when motor and wheel are lowered, providing a significant reduction of sharpening time. Sliding vise for proper sharpening of chisel chains. Complete with built-in lamp for improved visibility.



PROFESSIONAL USE

DOWN ANGLE

FROM 1/4" TO .404" CHAIN PITCH



P/N	VOLTAGE	RATED POWER	MAX SPEED	WEIGHT	CHAIN PITCH
1150925	230 V~ 50 Hz	214 W	2800 min ⁻¹	6,5 kg	1/4" ÷ .404"
1150935	120 V~ 60 Hz	300 W	3400 min ⁻¹		

PACKAGING



CARTON (1PC X)

CERTIFICATIONS

230 V~ 50 Hz



120 V~ 60 Hz



PROVIDED WITH FOLLOWING ITEMS

GRINDING WHEEL

- 1 pc. Thickness 3,2 mm for: 1/4" - .325" - 3/8" chains
- 1 pc. Thickness 4,7 mm for: .325" - 3/8" - .404" chains
- 1 pc. Thickness 6,0 mm for depth gauge



DRESSING BRICK

- 1 pc.



TEMPLATE

- 1 pc.



WRENCHES

- 1 pc. HEX. 4 mm
- 1 pc. HEX. 5 mm





highlights



SLIDING VICE

For some types of chains you need to correct the vice and arm working angles. You can make this adjustment simply by pulling the vice.



CHAIN CENTRING

This check ring nut can be turned based on the type of chain and enables you to centre it on the vice perfectly.

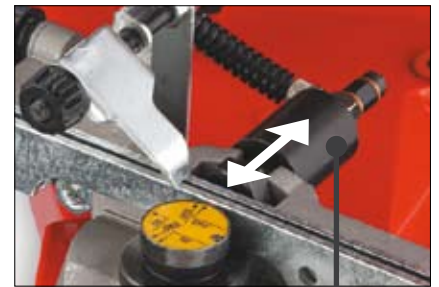

HYDRAULIC VICE

The hydraulic cylinder is activated as soon as the arm-motor is lowered. The vice closes automatically whenever the chain grinder is put in the working position.



SWITCH

This type of switch is disabled automatically in the case of a power supply failure.



LIGHT

The light is fitted next to the chain grinder and illuminates the whole work area perfectly.

Jolly chain grinder

Professional chain grinder for fast, accurate chain sharpening. Suitable for all chain pitches and types. Sharpens 3/4" pitch chain when fitted with attachment our P/N 1102900.

Up to 10° tilting vise for proper sharpening of chisel chains. Complete with built-in lampe for improved visibility.



PROFESSIONAL USE

DOWN ANGLE

FROM 1/4" TO .404" CHAIN PITCH

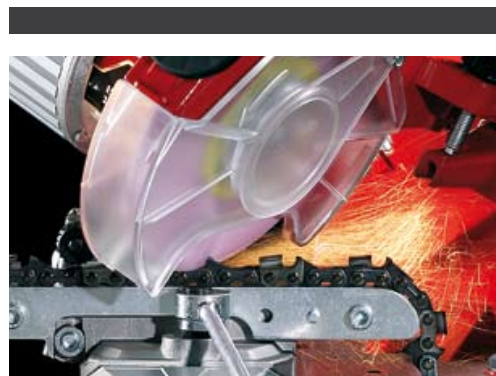

P/N	VOLTAGE	RATED POWER	MAX SPEED	WEIGHT	CHAIN PITCH
1135942	230 V~ 50 Hz	214 W	2800 min ⁻¹	6,0 kg	1/4" ÷ .404"
1136941	120 V~ 60 Hz	300 W	3400 min ⁻¹		
11359000	230 V~ 50 Hz	214 W	2800 min ⁻¹	6,0 kg	3/4"
1136931	120 V~ 60 Hz	300 W	3400 min ⁻¹		

PACKAGING



CARTON

ORDER MULTIPLES OF



4 PCS

CERTIFICATIONS

230 V~ 50 Hz



120 V~ 60 Hz



PROVIDED WITH FOLLOWING ITEMS

Only for:
11359000 and 1136931

GRINDING WHEEL

1 pc. Thickness 3,2 mm for: 1/4" - .325" - 3/8" chains
1 pc. Thickness 4,7 mm for: .325" - 3/8" - .404" chains
1 pc. Thickness 6,0 mm for depth gauge



DRESSING BRICK

1 pc.



TEMPLATE

1 pc.



WRENCHES

1 pc. HEX. 4 mm
1 pc. HEX. 5 mm



Only for:
11359000 and 1136931

GRINDING WHEEL

1 pc. Thickness 8 mm for: 3/4" chains



TEMPLATE

1 pc. 3/4" gauge template



MIDI Jolly

chain grinder

Compact and reliable grinder. Professional and accurate grinding performances.

The "MIDI JOLLY" features permanent-magnet motor capable to provide excellent performances even under the greatest strain.



P/N	VOLTAGE	RATED POWER	MAX SPEED	WEIGHT	CHAIN PITCH
1190910	230 V~ 50 Hz	85 W	5000 min ⁻¹	2,5 kg	1/4" ÷ .404"
1190915	120 V~ 60 Hz				

PACKAGING

 CARTON

ORDER MULTIPLES OF

 6 PCS

CERTIFICATIONS

230 V~ 50 Hz



PROVIDED WITH FOLLOWING ITEMS

GRINDING WHEEL
1 pc. Thickness 3,2 mm for: 1/4" - .325" chains



DRESSING BRICK
1 pc.



TEMPLATE
1 pc.



accessories



GRINDING WHEEL Th. 4,7 mm - P/N 1190052
GRINDING WHEEL Th. 6 mm - P/N 1190053

highlights



ADJUSTABLE VISE HANDLE

By pushing the button in the center of the vise handle, the handle can be disengaged and rotated to the position that is most convenient for the operation of the grinder. Increased visibility and ease of operation.

BABY Jolly

chain grinder

This unit allows you to sharpen sawchains without removing the chain from the bar. It combines professional characteristics such as precision and the high-power of the motor with the low-cost and handiness required for the DIY market.

Available also in a 12 V version for connecting to a car or tractor battery.



P/N	VOLTAGE	RATED POWER	MAX SPEED	WEIGHT	CHAIN PITCH
1195920	230 V~ 50 Hz				
1195915	120 V~ 60 Hz	85 W	5000 min ⁻¹	2,0 kg	1/4" ÷ .404"
1195910	12 V ---				

PACKAGING



CARTON

ORDER MULTIPLES OF



6 PCS

CERTIFICATIONS

230 V~ 50 Hz



12 V ---



accessories



GRINDING WHEEL Th. 4,7 mm

PROVIDED WITH FOLLOWING ITEMS

GRINDING WHEEL

1 pc. Thickness 3,2 mm for: 1/4" - .325" chains



DRESSING BRICK

1 pc.



















TEMPLATE





1 pc.



Grinding Wheels



SUITABLE TO	WHEEL P/N	FOR CHAIN PITCH					FOR DEPTH GAUGE	WHEEL SIZE			TYPE	Q.TY PER CARTON 	
		1/4"	.325"	3/8"	.404"	3/4"		Øext.	Øint.	Th.			
Jolly Star Super Jolly Jolly	1005231	●	●	●				145 mm (5-3/4")	22,2 mm (7/8")	3,2 mm (1/8")		18	
	1005233		●	●	●			145 mm (5-3/4")	22,2 mm (7/8")	4,7 mm (3/16")		14	
	1005232						●	145 mm (5-3/4")	22,2 mm (7/8")	6 mm (1/4")		12	
	01005000					●		145 mm (5-3/4")	22,2 mm (7/8")	8 mm (5/16")		15	
	01005001		●	●	●			145 mm (5-3/4")	22,2 mm (7/8")	4,7 mm (3/16")		14	
	01005015	●	●	●				145 mm (5-3/4")	22,2 mm (7/8")	3,2 mm (1/8")		18	
	01005014		●	●	●			145 mm (5-3/4")	22,2 mm (7/8")	4,7 mm (3/16")		14	
	01005003	●	●	●				145 mm (5-3/4")	22,2 mm (7/8")	3,2 mm (1/8")		40	
	01005004		●	●	●			145 mm (5-3/4")	22,2 mm (7/8")	4,7 mm (3/16")		25	
	01005005						●	145 mm (5-3/4")	22,2 mm (7/8")	6 mm (1/4")		20	
Midi Jolly Easy Grinder Sharp boy Baby Jolly	1190051	●	●	●				105 mm (4-1/8")	22,2 mm (7/8")	3,2 mm (1/8")		27	
	1190052		●	●	●			105 mm (4-1/8")	22,2 mm (7/8")	4,7 mm (3/16")		23	
	1190053						●	105 mm (4-1/8")	22,2 mm (7/8")	6 mm (1/4")		20	
	01005006	●	●	●				105 mm (4-1/8")	22,2 mm (7/8")	3,2 mm (1/8")		40	
	01005007		●	●	●			105 mm (4-1/8")	22,2 mm (7/8")	4,7 mm (3/16")		25	
Mini Jolly	1185148	●	●	●				100 mm (4-7/8")	16 mm (5/8")	3,2 mm (1/8")		27	
	1185149			●	●			100 mm (4-7/8")	16 mm (5/8")	4,7 mm (3/16")		23	
	1185150						●	100 mm (4-7/8")	16 mm (5/8")	6,4 mm (1/4")		20	
EFFELLE suitable for PROGRESS	1005033	●	●	●				123 mm (4.84")	22,2 mm (7/8")	3 mm (1/8")		28	
	1005034		●	●	●			123 mm (4.84")	22,2 mm (7/8")	4,5 mm (3/16")		24	
	1005032						●	123 mm (4.84")	22,2 mm (7/8")	7 mm (.275")		15	

Grinding wheels specification	COLOR				
	CONSUMPTION	Low	Medium	Medium	High
	ABRASION CAPABILITY	Low	Medium	Medium	High
	CHAIN FINISHING	Good	Medium	Medium	Rough

Special Vises



To be fitted to **Jolly** chain grinder body, for **3/4"** pitch chains.

P/N	FOR
1102900	3/4" Pitch chains

PROVIDED WITH GRINDING WHEELS AND TEMPLATE

Grinding wheel for 3/4" pitch chains



3/4" Gauge template



PACKAGING

CARTON

ORDER MULTIPLES OF



To be fitted to **Jolly** and **JollyStar** chain grinder body, for hedge trimmer steel blades.

P/N	FOR
1085900	Steel blades

PACKAGING

CARTON

ORDER MULTIPLES OF



NEW

To be fitted to **Jolly** and **JollyStar** chain grinder body, for hedge trimmer blade grinding.

P/N	FOR
1177900	Hedge trimmer blades

PACKAGING

CARTON

ORDER MULTIPLES OF



Accessories for chain grinders



P/N	DESCRIPTION
-----	-------------

1005040 Dressing brick

PACKAGING
NYLON BAG

ORDER MULTIPLES OF
 20 PCS

P/N	DESCRIPTION
-----	-------------

1112001 Dressing brick

PACKAGING
CARTON

ORDER MULTIPLES OF
 10 PCS

P/N	DESCRIPTION
-----	-------------

3052004 Wrench 4mm

3052005 Wrench 5mm

PACKAGING
NYLON BAG

ORDER MULTIPLES OF
 10 PCS

P/N	DESCRIPTION
-----	-------------

D00400000 3/4" Gauge template

PACKAGING
NYLON BAG

ORDER MULTIPLES OF
 10 PCS

FOR JOLLY AND JOLLY STAR

Chain grinder is installed on stand properly connected to a treadle for pedal use.

P/N	DESCRIPTION
-----	-------------

1122915 Chain grinder stand

PACKAGING
CARTON



ORDER MULTIPLES OF
 1 PC

DELuxe

manual sharpener



For precision saw chain filing with 6"-8" round files as well as flat and triangular depth gauge files. Professional model.

P/N	DESCRIPTION
1147981	De Luxe
PACKAGING	ORDER MULTIPLES OF
CLAMSHELL	 24 PCS
	



P/N	DESCRIPTION
1147978	De Luxe
PACKAGING	ORDER MULTIPLES OF
BULK	 50 PCS

SUPERRapid

manual sharpener



For precision saw chain filing with 6"- 8" round files as well as flat and triangular depth gauge files.

P/N	DESCRIPTION
1107902	Super Rapid
PACKAGING	ORDER MULTIPLES OF
CLAMSHELL	 30 PCS
	

P/N	DESCRIPTION
1107904	Super Rapid
PACKAGING	ORDER MULTIPLES OF
BULK	 90 PCS



Filing Vise



For professional and hobby users. Usefull in the field.
Holds saw guide bar firmly when filing. Filing angle marks.

P/N	DESCRIPTION
1090900	Filing Vise

PACKAGING
NYLON BAG

ORDER MULTIPLES OF
 12 PCS

NEW



P/N	DESCRIPTION
10909000	Filing Vise

Generative EAN13 code available.

PACKAGING
 CLAMSHELL

ORDER MULTIPLES OF
 12 PCS

Magnetic Filing Angle Guide



Plastic item with 30°/35° angle marks on one side and 25°/35° angle on the other side; the 2 magnets keep it on the guide bar.

P/N	DESCRIPTION	PACKAGING	
1082901A	Filing guide 25°-30°	CARTON	200 PCS
1082902	Filing guide 30°-35°	CARTON	200 PCS

Dept Gauge Jointers

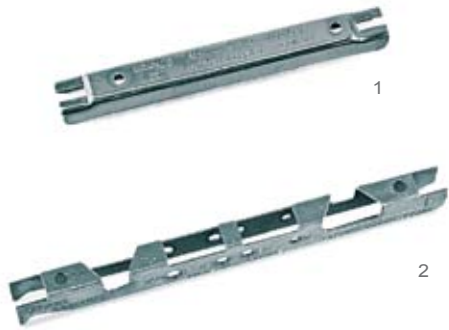

For an accurate depth control setting; 2 can be used as bar groove cleaner, file angles and file gauge.

P/N	DEPTH SETTING	
	IN	mm
1 1018001	.025" - .030"	0,65 - 0,75
2 1018003	.025" - .030" .035" - .040"	0,65 - 0,75 0,90 - 1,00

PACKAGING

NYLON BAG

ORDER MULTIPLES OF



50 PCS

Bar Groove Cleaner



This tool is useful for bar maintenance. Clears grooves and oil holes.

P/N	DESCRIPTION
1017001	Bar groove cleaner

PACKAGING

NYLON BAG

ORDER MULTIPLES OF



300 PCS

File Handles



Comfortable plastic made file handles. Fits round and flat file.

P/N	DESCRIPTION	PACKAGING	
1013006	Red, with 30° and 35° filing angles	BULK	250 PCS
1013020	Black, professional	BULK	400 PCS

Flat File Holders

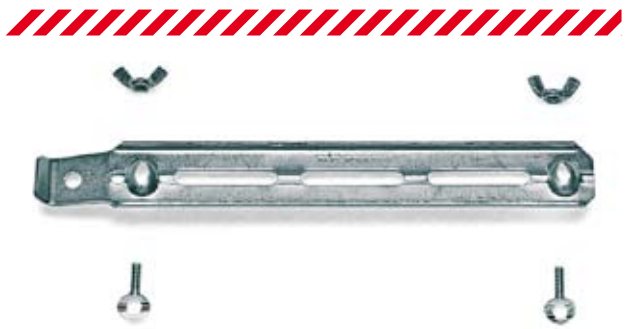

Without handle and file

P/N	ROUND FILE Ø		FILE LENGTH	
	IN	mm	IN	mm
1010942	5/32"	4,0		
1019903	11/64"	4,5		
1011942	3/16"	4,8	8"	200
10139003	13/64"	5,2		
1012942	7/32"	5,5		

PACKAGING

BOX

ORDER MULTIPLES OF



100 PCS

Chain Saw Files



NEW



Regularly sharpening tools with this files, increase efficiency, enhance comfort, improve safety, cut back on energy consumption, reduce wear and tear.

- Round chain saw files, smooth.
- Sharp edges, fine points.
- Made from chrome steel.
- Hardness 66 HRC.

P/N	ROUND FILE Ø		FILE LENGTH	
	IN	mm	IN	mm
1010026	5/32"	4,0		
1011014	11/64"	4,5		
1011015	3/16"	4,8	8"	200
L0020000	13/64"	5,2		
1012009	7/32"	5,5		

PACKAGING



BOX (12X)

ORDER MULTIPLES OF



300 PCS

Push Rod



P/N	DESCRIPTION
01013000	Push rod

PACKAGING

BOX

ORDER MULTIPLES OF



50 PCS

Flat File Holders



Detail - 15° mark



NEW

For quick filing of any saw chain type and pitch. Complete slowing 25°/30° and 35° filing angle marks - 10° bent and for most accurate filing assembled with handle and file.

P/N	ROUND FILE Ø		FILE LENGTH	
	IN	mm	IN	mm
1010963	5/32"	4,0		215
1019901	11/64"	4,5		
1011966	3/16"	4,8	8"	200
10139001	13/64"	5,2		
1012962	7/32"	5,5		

PACKAGING

BOX

ORDER MULTIPLES OF



50 PCS

P/N	ROUND FILE Ø		FILE LENGTH	
	IN	mm	IN	mm
10109002	5/32"	4,0		215
10199002	11/64"	4,5		
10119002	3/16"	4,8	8"	200
10199003	13/64"	5,2		
10129002	7/32"	5,5		

Generative EAN13 code available.

PACKAGING

CLAMSHELL



ORDER MULTIPLES OF



50 PCS

Filing Kit



For quick filing of any saw chain type and pitch. Complete with handle and push rod.

P/N	ROUND FILE Ø		FILE LENGTH	
	IN	mm	IN	mm
10109000	5/32"	4,0		215
10199000	11/64"	4,5		
10119000	3/16"	4,8	8"	200
10139000	13/64"	5,2		
10129000	7/32"	5,5		

PACKAGING

BOX



ORDER MULTIPLES OF



12 PCS



Filing Kit



NEW



This kit for hand maintenance of chain, includes:

- one round file for chain top plate maintenance
- one flat file for depth gauge maintenance
- one depth gauge jointer
- two file handles

P/N	ROUND FILE Ø		FILE LENGTH	
	IN	mm	IN	mm
10829004	5/32"	4,0		215
10829007	11/64"	4,5		
10829005	3/16"	4,8	8"	200
10829008	13/64"	5,2		
10829006	7/32"	5,5		

Generative EAN13 code available.

PACKAGING



CLAMSHELL

ORDER MULTIPLES OF



40 PCS

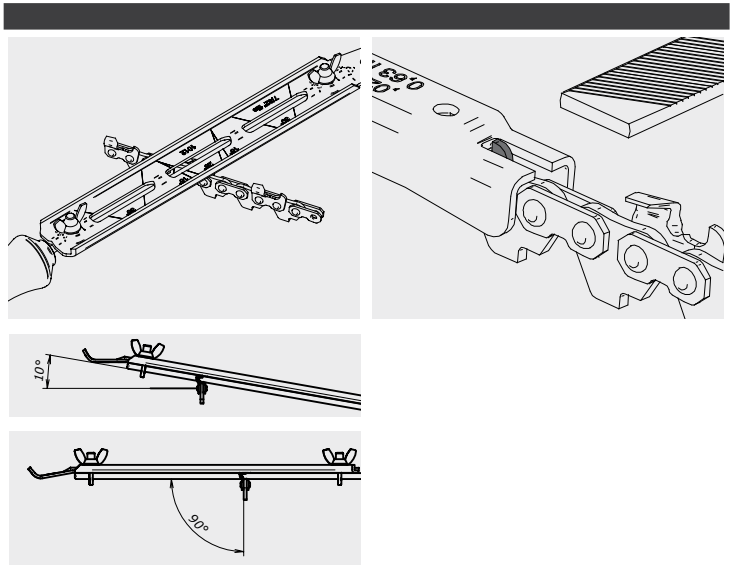

Steel Chain Breaker



Bench type for shop use. With operating lever for fast and easy chain breaking. Complete anvil 1020070, punch 1020033E and punch 1020189.

P/N	DESCRIPTION
-----	-------------

1020961	Chain breaker
---------	---------------

PACKAGING



CARTON

ORDER MULTIPLES OF



10 PCS



PROFESSIONAL USE



FROM 1/4" TO .404" CHAIN PITCH



PROVIDED WITH FOLLOWING ITEMS

1 pc. ADJUSTABLE ANVIL



new

1 pc. PUNCH
1.1 - .043"
gauge chains



1 pc. PUNCH
1/4" - 3/8" - .404" chains



1 pc. WRENCH
HEX. 4 mm



Nudular Cast Iron Chain Breaker



Sturdy construction achieved with high quality nodular cast iron. Easily 3/4" chain breaking by means of well designed cam shaft. Suitable for any kind of chain pitch using kit P/N 1020184.

P/N	DESCRIPTION
1020980	Heavy duty chain breaker

PACKAGING



CARTON

ORDER MULTIPLES OF



1 PC



PROFESSIONAL USE



FROM 1/4" TO 3/4" CHAIN PITCH



PROVIDED WITH FOLLOWING ITEMS

1 pc. ADJUSTABLE ANVIL



new

1 pc. PUNCH
1.1 - .043"
gauge chains



1 pc. PUNCH
1/4" - 3/8" - .404" chains



1 pc. WRENCH
HEX. 4 mm



1 pc. CHAIN ANVIL 3/4"



1 pc. PUNCH 3/4"



3/4" PITCH CHAIN

3/4" Pitch Chain



Adjustable Anvil



NEW

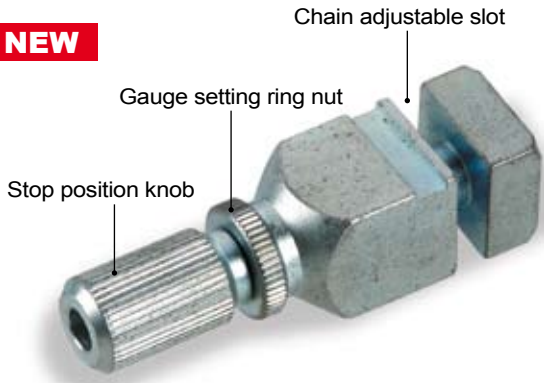

Adjustable chain anvil for chain breakers (1/4" ÷ 3/4" chain pitch).

- Stop position adjustment by means of locking knob and jaws gauge setting by means of additional ring nut.
- Special treated steel for lower material wear and longer use.

P/N	DESCRIPTION
1020070	Adjustable anvil



ORDER MULTIPLES OF

10 PCS

Slotted Anvil

For Oregon Chains



New slotted anvil. The six slots ensures a perfect positioning for breaking most Oregon chainsaw chain models.

P/N	DESCRIPTION
1020173	Slotted anvil



ORDER MULTIPLES OF

10 PCS

3/4" Pitch Chain Anvil



New slotted anvil for 3/4" pitch chain.

P/N	DESCRIPTION
1020181	3/4" pitch chain anvil

ORDER MULTIPLES OF

5 PCS

Punches



For 1/4" - 3/8" - .325" - .404" chains.

P/N	DESCRIPTION
1020033E	Punch

ORDER MULTIPLES OF



Punch for 1.1 mm (.043") gauge chains.

P/N	DESCRIPTION
1020189	Punch

ORDER MULTIPLES OF



Punch for 3/4" pitch chain.

P/N	DESCRIPTION
1020150	Punch

ORDER MULTIPLES OF



Pocket Chain Breaker



An hand operated pocket chain breaker which provides a convenient method of repairing chains on the field; complete with plastic holster. For: 3/8" - .404" - 7/16" - 1/2" pitch chain.

P/N	DESCRIPTION
1030900	Pocket chain breaker

PACKAGING

PLASTIC
HOLSTER

ORDER MULTIPLES OF



Steel Rivet Spinner



With built-in thrust bearing for minimum friction, giving fast and effortless spinning. Complete with take-up handle and spinner insert for .3/8" - .404" chains.



P/N	DESCRIPTION
1025950	Rivet spinner

PACKAGING



CARTON

ORDER MULTIPLES OF



10 PCS



PROFESSIONAL USE



FROM 3/8" TO .404" CHAIN PITCH

PROVIDED WITH FOLLOWING ITEMS

1 pc.	SPINNER INSERT 3/8" - .404" chains	
1 pc.	TAKE-UP HANDLE 3/8" - .404" chains	

Nudular Cast Iron Rivet Spinner



Sturdy construction achive with high quality nodular cast iron. Easy 3/4" chain pitch riveting by means of thrust and needle bearings. Suitable for any kind of chain pitch.



P/N	DESCRIPTION
1025970	Heavy duty rivet spinner

PACKAGING



CARTON

ORDER MULTIPLES OF



1 PC



PROFESSIONAL USE



FROM 1/4" TO 3/4" CHAIN PITCH

PROVIDED WITH FOLLOWING ITEMS

1 pc.	SPINNER INSERT 3/8" - .404" chains	
1 pc.	SPINNER INSERT 1/4" - .325" chains	
1 pc.	TAKE-UP HANDLE for: 1/4" - .325" chains for: 3/8" - .404" chains	
1 pc.	INSERT 3/4"	
1 pc.	THRUST BOLT 3/4"	

3/4" PITCH CHAIN



3/4" Pitch Chain

Take-up Handles



For Rivet Spinner 1025950

P/N	DESCRIPTION
1 1026001D	For 1/4" - .325" chains
2 1027001D	For .3/8" - .404" chains

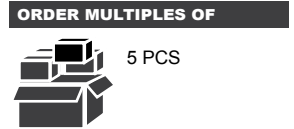

For Rivet Spinner 1025970

P/N	DESCRIPTION
1 1025091	For 1/4" - .325" chains
2 1025092	For 3/8" - .404" chains
3 1025106	Thrust bolt for 3/4" chains

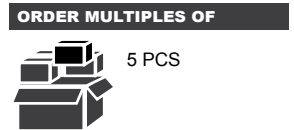

3/4" Pitch Chain

Spinner Inserts



For Rivet Spinner 1025950 - 1025970

P/N	DESCRIPTION	
1 1028002D	For 1/4" - .325" chains	10 PCS
2 1029001E	For .3/8" - .404" chains	
3 1025105	Insert 3/4" chains (only for 1025970)	5 PCS

3/4" Pitch Chain



RIVETMaster

electric rivet spinner



This electric rivet spinner is a professional riveting machine specifically designed for people who repair and sell large quantities of chain-saw chains.

The extra-hard metal head provides excellent final results. The stable and robust supporting structure features adjustable feet.

P/N	VOLTAGE	RATED POWER	MAX SPEED	WEIGHT	CHAIN PITCH
1131925	230 V~ 50 Hz	300 W	1420 min ⁻¹	28 kg	.325" ÷ .404"
1131920	120 V~ 60 Hz	400 W	1700 min ⁻¹	28 kg	.325" ÷ .404"

PACKAGING

CARTON

1 BOX FOR E-MOTOR
1 BOX FOR TRIPOD

ORDER MULTIPLES OF



PROFESSIONAL USE



1/4" - 90SG - 91 - 25AP - .325"
3/8" - .404" - HARVESTER
CHAIN PITCH

PROVIDED WITH FOLLOWING ITEMS

1 pc. KIT SPINROLL-ANVIL "A"
P/N 1131130

Suitable for chains pitch:
.325" - 3/8" - .404" - HARVESTER



1 pc. KIT SPINROLL-ANVIL "B"
P/N 1131131

Suitable for chains pitch:
1/4" - 90SG - 91 - 25AP



CERTIFICATIONS

230 V~ 50 Hz



120 V~ 60 Hz

Piston Stop



P/N	DESCRIPTION
1111007	Universal nylon piston stop

PACKAGING
NYLON BAG

ORDER MULTIPLES OF
 50 PCS

P/N	DESCRIPTION
1111003	Nylon piston stop

PACKAGING
NYLON BAG

ORDER MULTIPLES OF
 50 PCS

P/N	DESCRIPTION
1111008	Metal piston stop

PACKAGING
NYLON BAG

ORDER MULTIPLES OF
 50 PCS

Piston Ring Clam Set



Useful for assembling pistons and cylinders. 4 size of clamps.
Pistons from Ø32 up to Ø58 mm.

P/N	DESCRIPTION
1042901	Set

PACKAGING
PLASTIC HOLSTER

ORDER MULTIPLES OF
 50 PCS

Pressure Gauge



Gauge for carburetor and cylinder testing.

P/N	DESCRIPTION
1043900	Pressure gauge

PACKAGING
BOX

ORDER MULTIPLES OF
 1 PC

Pressure Gauge Kit



Professional carburetor service kit, with pressure gauge, special tools and punches.

P/N	DESCRIPTION
1081900	Pressure gauge kit

PACKAGING
BOX

ORDER MULTIPLES OF
 1 PC

Grease Guns



Handy plastic item for sprocket tip guide bars; refillable plunger type.

P/N	DESCRIPTION	PACKAGING	
1 1108001	GREASE GUN	CARTON	25 PCS
2 01108000	GREASE GUN	NEUTRAL CARTON	800 PCS

Oil and grease gun for chain saw, specially designed for sprocket bar tip. Metal tip, diam. 35 mm; polypropylene body. Capacity: 100 gr.

P/N	DESCRIPTION
1108025	Grease gun

PACKAGING	ORDER MULTIPLES OF
BOX	 50 PCS

Bar Guards



For safety purposes and to protect the saw bar and chain.

P/N	LENGTH IN	mm
1144033	12" x 3 9/16"	300 x 91
1144038	14" x 3 9/16"	350 x 91
1144156	16" x 3 9/16"	400 x 91
1144043	16" x 4 3/4"	400 x 120
1144048	18" x 4 3/4"	450 x 120
1144053	20" x 4 3/4"	500 x 120

PACKAGING	ORDER MULTIPLES OF
CARTON	 48 PCS

Wedges



NEW

Tough plastic; durable and safe felling and bucking without damaging the chain.
 Double tapered new line of bucking and falling wedges.
 Rough surface for more anti kick-back safety and higher lifting force

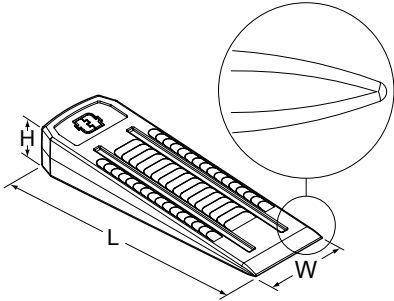

P/N	DIMENSIONS			PROFILE	WEIGHT	PACKAGING	
	L mm	W mm	H mm				
C03400000	183	64,5	24	A	0,20 kg	CLAMSHELL	12 PCS
C03400001	231	70	30	B	0,35 kg	CLAMSHELL	12 PCS
C03400002	243	73	39,3	A	0,50 kg	CLAMSHELL	12 PCS

Generative EAN13 code available.

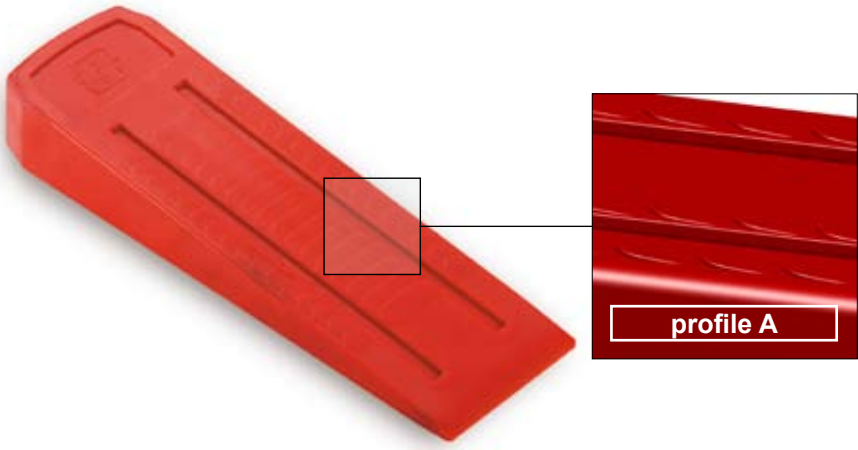
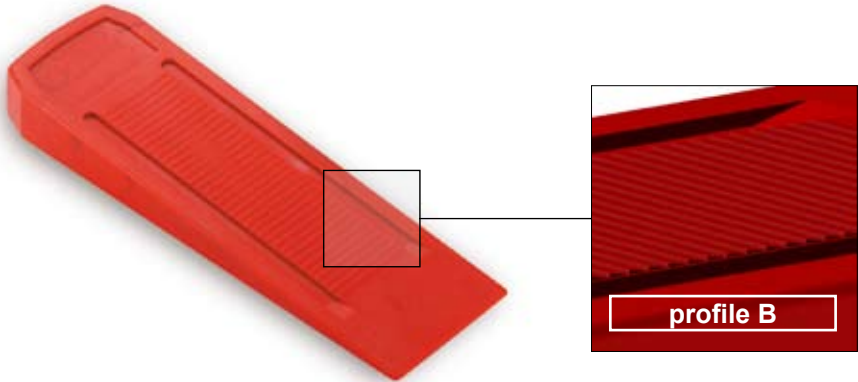
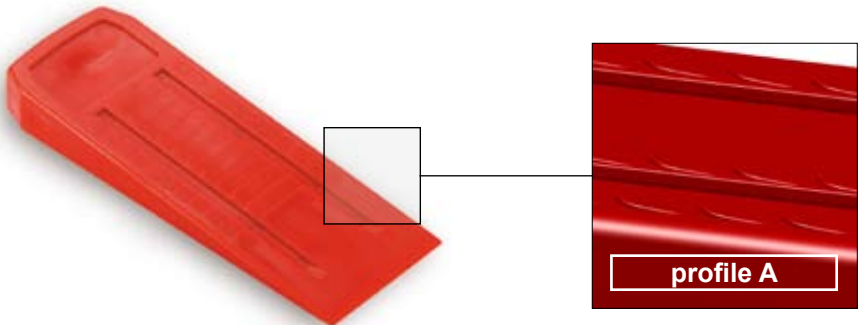

Wedges



Tough plastic; durable and safe felling and bucking without damaging the chain.

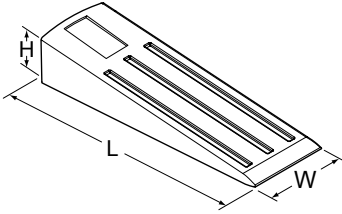

P/N	DIMENSIONS			PROFILE	PACKAGING	
	L mm	W mm	H mm			
1055903A	140	70	27		BULK	35 PCS
1055901A	190	70	26	C	BULK	25 PCS
1055904A	265	77	29		BULK	14 PCS

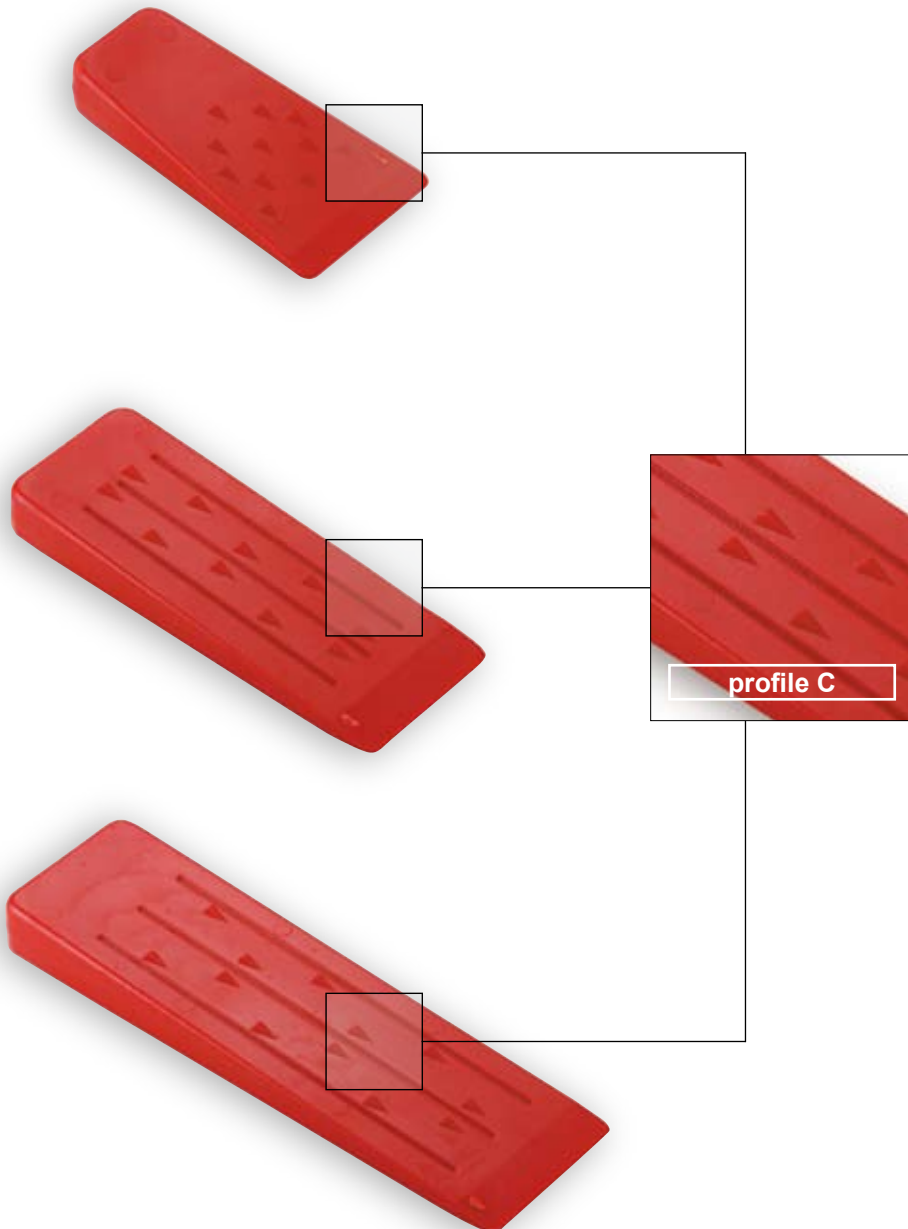

Lawnmower Blade Balancer



Improved version for any kind of lawnmower blade - 6 magnets allow higher stability.

P/N	DESCRIPTION
05800000	Lawnmower blade balancer

PACKAGING

BOX

ORDER MULTIPLES OF



Emery Band



For polishing.

P/N	DESCRIPTION
1075001	Emery band

PACKAGING

BULK

ORDER MULTIPLES OF

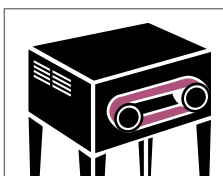

brushcutter accessories



Whips	34
Whips	35
Whips	36
PROwhips	37
PROdisc	38
WhipsSF25	39
Easyload	40
Easyload	41
Easyload	42
Tap-n-go	43
Tap-n-go	44
Tap-n-go	45
SuperPro	46
Tap-n-go	47
MINITap-n-go	48
ManualHeadProType	49
GuideListForNylonHeadAdaptors	50
GuideListForNylonHeadAdaptors	51
GuideListForNylonHeadAdaptors	52
RoundNylonLine	53
RoundNylonLine	54
RoundNylonLine	55
SquareNylonLine	56
SquareNylonLine	57
SquareNylonLine	58
RoundNylonLine	59
HelicoidalNylonLine	60
Pro-TrimDisk	61
NylonBlades	62
SteelBlades	63
SteelBlades	64
SteelBlades	65
SteelBlades	66
SteelBlades	67
MetalNetFaceShields	68
MetalNetFaceShields	69
PolycarbonateFaceShields	70
PolycarbonateFaceShields	71
EarMuffs	72
Goggles	72
SafetyHelmet	73
ShinGuards	73
BrushcutterShoulderStraps	74
BladeGuard	75
BladeGuard	76
BladeSupport	76
Troppopieno	77
PlasticCans	77
PlasticCans	78
FunnelAssyFilter	79
GreaseStickersForBevelGearPairs	79

PROVVIS.





**brushcutter
accessories**

Forestry and gardening accessories

LEGENDA



Universal mounting without adaptor.



Displacement of the brushcutter on which the application is used.



Applications for:
traditional outdoor
gardening

Ideal for cutting:
grass and small weeds.



Applications for:
heavy duty outdoor
gardening

Ideal for cutting:
grass and large weeds, also around
obstacles.



Applications for:
heavy duty outdoor
gardening

Ideal for cutting:
grass, weeds, reeds, light brush and
shrubs.



Applications for:
heavy duty outdoor
gardening and forestry

Ideal for cutting:
bushes, dense weeds and undergrowth



Applications for:
forestry

Ideal for cutting:
undergrowth with thinning saplings



Whips trimmer head

universal mounting



Trimmer head, universal mounting without adaptor, centering bore for both 20-25,4 mm. Delivered complete with: 6 nylon whips of $\varnothing=3\text{mm}$ and Length=300mm each / kit of adaptor washers / reduction rings. Suggested for trimmers up to 33 cc.

> Larger **plastic** knob for more comfortable assembling and disassembling.



OPTIONS

2 LINES



3 LINES



P/N

DESCRIPTION

5090901 Nylon / nylon head

Generative EAN13 code available.

PACKAGING

NYLON BAG

ORDER MULTIPLES OF



50 PCS

REPLACEMENT PARTS

\varnothing 3 mm Set of 50 nylon whips each, 300 mm long

P/N 5200040



\varnothing 3,3 mm Set of 50 nylon whips each, 300 mm long

P/N 5200041



Plastic knob \varnothing 80mm

P/N 5090012



Kit of adaptor washers and reduction rings

P/N K00401008



NEW

Whips trimmer head

universal mounting



Professional trimmer head, universal mounting without adaptor, centering bore for both 20-25,4 mm.

Delivered complete with: 10 nylon whips of $\varnothing=3,3\text{mm}$ and Length=300mm each / kit of adaptor washers / reduction rings.

Suggested for brushcutters over 33 cc.

- Improved overall look for display presentation.
- Easier assembling and disassembling.
- Redesigned fixed-line chamfers of lines attachment slots, reduces fixed-line strain and breakage cases.

> Larger **plastic** knob for more comfortable assembling and disassembling.

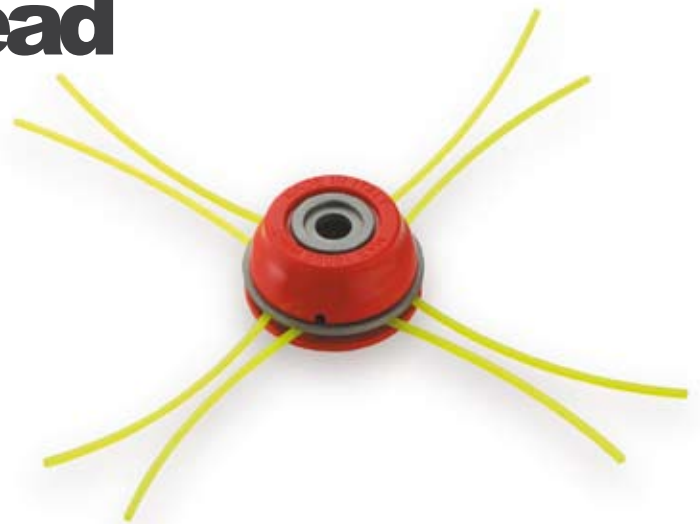
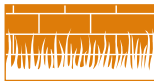

OPTIONS

2 LINES

4 LINES



P/N DESCRIPTION

P/N	DESCRIPTION
50909007	Aluminium / nylon head

Generative EAN13 code available.

PACKAGING

NYLON BAG

ORDER MULTIPLES OF



50 PCS

REPLACEMENT PARTS

\varnothing 3 mm Set of 50 nylon whips each, 300 mm long

P/N 5200040



\varnothing 3,3 mm Set of 50 nylon whips each, 300 mm long

P/N 5200041



Plastic knob \varnothing 80mm

P/N 5090012



Kit of adaptor washers and reduction rings

P/N K00401008

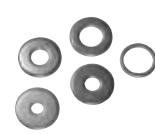

Whips trimmer head

universal mounting



Professional trimmer head, universal mounting without adaptor, centering bore for both 20-25,4 mm.

Delivered complete with: 10 nylon whips of $\varnothing=3,3\text{mm}$ and Length=300mm each / kit of adaptor washers / reduction rings.

Suggested for brushcutters over 33 cc.

- Improved overall look for display presentation.
- Easier assembling and disassembling.
- Redesigned fixed-line chamfers of lines attachment slots, reduces fixed-line strain and breakage cases.

> Larger **aluminium** knob for more comfortable assembling and disassembling.



OPTIONS

2 LINES



4 LINES



P/N

DESCRIPTION

50909006

Aluminium / aluminium head

Generative EAN13 code available.

PACKAGING

NYLON BAG

ORDER MULTIPLES OF



50 PCS

REPLACEMENT PARTS

\varnothing 3 mm Set of 50 nylon whips each, 300 mm long

P/N 5200040



\varnothing 3,3 mm Set of 50 nylon whips each, 300 mm long

P/N 5200041



Aluminium knob \varnothing 80mm

P/N 5090014



Kit of adaptor washers and reduction rings

P/N K00401008

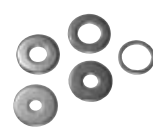

Whips trimmer head

universal mounting

New concept patented nylon head for brushcutters up to 33 cc. Modern design combined with high cutting performance and minimum weight. Universal mounting without adaptor, centering bore for both 20-25,4 mm. Delivered complete with: 4 nylon whips of $\varnothing=3\text{mm}$ and Length=300mm each / kit of adaptor washers / reduction rings. Suggested for brushcutters up to 33 c.c.

> Larger knob for more comfortable assembling and disassembling.

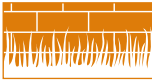

OPTIONS

2 LINES

4 LINES



P/N

DESCRIPTION

5090912 Nylon head

Generative EAN13 code available.

PACKAGING

NYLON BAG

ORDER MULTIPLES OF



REPLACEMENT PARTS

\varnothing 3 mm Set of 50 nylon whips each, 300 mm long

P/N 5200040



\varnothing 3,3 mm Set of 50 nylon whips each, 300 mm long

P/N 5200041



Kit of adaptor washers and reduction rings

P/N K00401008

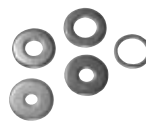

Whips

trimmer head - universal mounting



Professional trimmer head, universal mounting without adaptor, centering bore for both 20-25,4 mm. Multi stage line extension for mulching purpose. Delivered complete with: 10 nylon whips of $\varnothing=3,3\text{mm}$ and Length=300mm each / kit of adaptor washers / reduction rings.

- Improved overall look for display presentation.
- Easier assembling and disassembling.
- Redesigned fixed-line chamfers of lines attachment slots, reduces fixed-line strain and breakage cases.
- Larger knob for more comfortable assembling and disassembling.

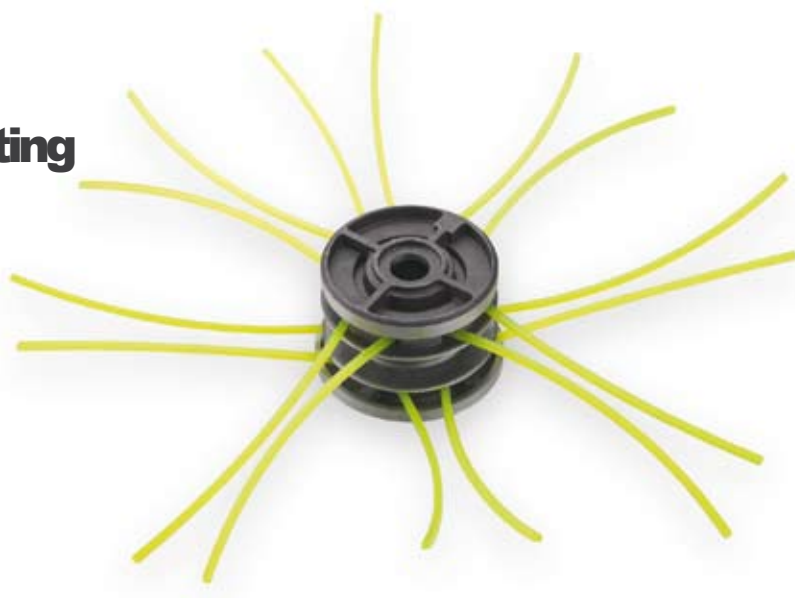
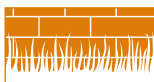

OPTIONS

4 LINES



8 LINES



P/N DESCRIPTION

5090911 Aluminium / aluminium head

Generative EAN13 code available.

PACKAGING

NYLON BAG

ORDER MULTIPLES OF



REPLACEMENT PARTS

\varnothing 3 mm Set of 50 nylon whips each, 300 mm long

P/N 5200040



\varnothing 3,3 mm Set of 50 nylon whips each, 300 mm long

P/N 5200041



Aluminium knob \varnothing 80mm

P/N 5090014



Kit of adaptor washers and reduction rings

P/N K00401008



PROWhips

trimmer head - universal mounting



Most comfortable manual head disassembling operation for easy fixed line loading.

Cross-over lines ensures higher line resistance and flexibility.

Centering bore for both 20-25,4 mm.

> Larger knob for more comfortable assembling and disassembling.



OPTIONS

2 LINES

4 LINES



P/N DESCRIPTION

50909005 Aluminium / aluminium head

Generative EAN13 code available.

PACKAGING
NYLON BAG

ORDER MULTIPLES OF
50 PCS

HIGHLIGHTS

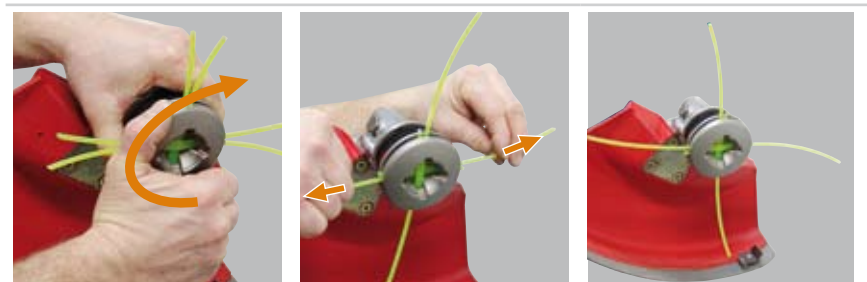
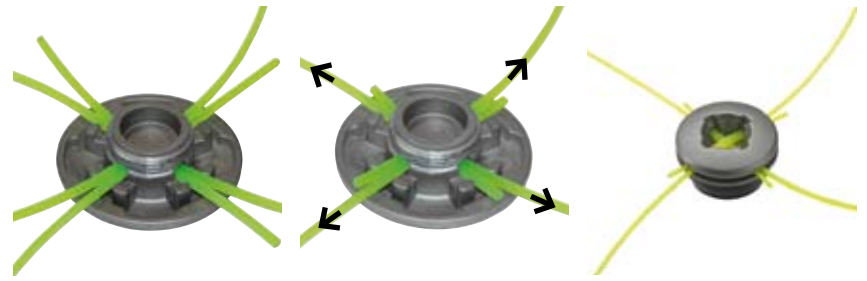

REPLACEMENT PARTS



∅ 3 mm Set of 50 nylon whips each, 300 mm long.
P/N 5200040

∅ 3,3 mm Set of 50 nylon whips each, 300 mm long.
P/N 5200041



Aluminium knob ∅80mm.
P/N C00012017



Kit of adaptor washers and reduction rings.
P/N K00401008

SF25

trimmer head - universal mounting

PATENT PENDING

Wide size head for more precise grass cutting and turf care.

Patented fixed line insertion and clamping.

Easy maintenance and top results for demanding landscapers.

Complete with kit of adaptor washers.

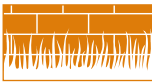

PREPARATION

1



For optimal results, use square nylon whips length 400mm

2

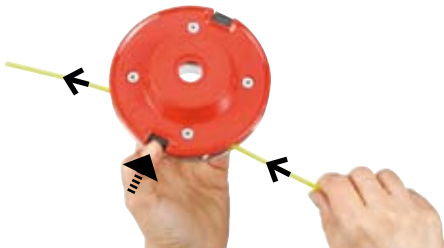

Press in the lateral metal buttons and insert new pre-cut whip

3

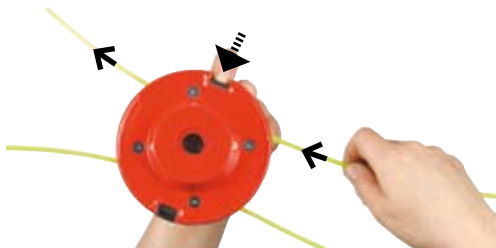

Ensure that the length of whip is the same of both side of the head, and beginning work!

P/N

DESCRIPTION

50619000

Aluminium / nylon head

PACKAGING



CLAMSHELL

ORDER MULTIPLES OF



20 PCS

REPLACEMENT PARTS



∅ 3 mm Set of 25 nylon whips each, 400 mm long.

P/N 5200230



Kit of adaptor washers and reduction rings.

P/N K00401008

PRODisc

trimmer head - universal mounting



Trimmer head evolution:

One swing blade head for four different purposes.

Centering bore for both 20-25,4 mm

- Worm shaped blade: handy and resistant
- knife shaped blade: best cut performance
- Larger knob for more comfortable assembling and disassembling.

Delivered complete with: 4 worm shaped blades, 4 knife shaped blades and kit of adaptor washers.

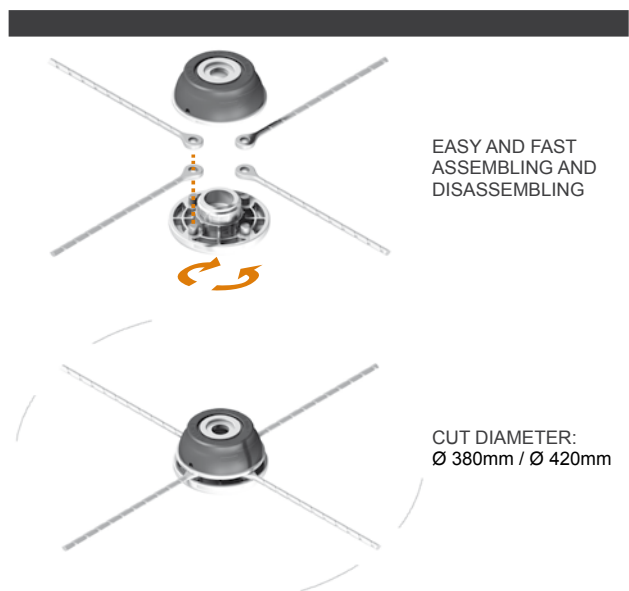
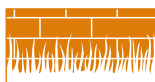

P/N	DESCRIPTION
50259000	Aluminium / aluminium head - Cutting Ø 380mm
50259004	Aluminium / aluminium head - Cutting Ø 420mm

Generative EAN13 code available.

PACKAGING
NYLON BAG

ORDER MULTIPLES OF
50 PCS

REPLACEMENT PARTS

Spiral shaped blade
P/N 05220000 L = 150mm (16 PCS)
P/N 05220001 L = 170mm (16 PCS)

Knife shaped blade
P/N 05220002 L = 150mm (16 PCS)
P/N 05220003 L = 170mm (16 PCS)

Aluminium knob Ø85mm
P/N C00012019

Kit of adaptor washers and reduction rings
P/N K00401008

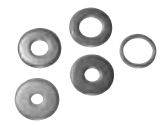



Replacement parts for whips trimmer heads



suitable for:
Whips Trimmer Head series

suitable for: SF25 only



P/N	DESCRIPTION
5200040	∅ 3 mm Set of 50 nylon whips each, 300 mm long
5200041	∅ 3,3 mm Set of 50 nylon whips each, 300 mm long
5200230	∅ 3 mm Set of 25 nylon whips each, 400 mm long.

PACKAGING	ORDER MULTIPLES OF
 NYLON BAG	 150 PCS → 5200040 50 PCS → 5200041 50 PCS → 5200230



suitable for:
ProDisc only

P/N	DESCRIPTION
1 0522000	Set of 16 Spiral shaped blades each, 150 mm long
1 0522001	Set of 16 Spiral shaped blades each, 170 mm long
2 0522002	Set of 16 Knife shaped blades each, 150 mm long
2 0522003	Set of 16 Knife shaped blades each, 170 mm long

PACKAGING	ORDER MULTIPLES OF
 NYLON BAG	 50 PCS

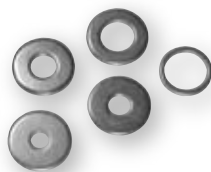

P/N	DESCRIPTION
K00401008	Kit of adaptor washers and reduction rings

PACKAGING	ORDER MULTIPLES OF
NYLON BAG	 50 PCS

Whips trimmer heads adaptor



Fits HU only

P/N	DESCRIPTION
5090019	Taper adaptor (fits HU only)

PACKAGING	ORDER MULTIPLES OF
NYLON BAG	 10 PCS

PATENT PENDING

NEW

EASYLoad

tap-n-go trimmer head



BEST PERFORMING TRIMMER HEAD

Combines the Tecomec traditional operation reliability with an outstanding and innovative line loading system. Sturdy construction confirmed by the heaviest internal and severe OEM's field tests.



Ø 109 mm



Ø 130 mm

HIGHLIGHTS

► Easy line refilling without disassembling any part of the trimmer head.



> Insert line from the one eylet to the opposite one.



> Turn the knob.



> Pull the line on both ends.



> Complete line winding by turning the knob.

► Heavy duty knob. Strong and bumps resistant.



Ø 130 - Aluminium

► By means of the new "patented" Tecomec system the only turning of cover knob to the mark clearly shown makes possible the line reloading through the eyelets.



► Pawl protection shield



Ø 109 - Plastic



EASYLoad

tap-n-go trimmer head Ø109

Double line nylon head Ø109 mm complete with adaptor bolt.



Ø 109 mm

P/N	DESCRIPTION
50719026	Tap-n-go "MD EL" head M8x1,25 LH.M.(fits EMAK only)
50719027	Tap-n-go "MD EL" head M8x1,25 LH.F.
50719014	Tap-n-go "MD EL" head M 8x1,25 LH.M.
50719028	Tap-n-go "MD EL" head M10x1,00 LH.F. (fits STHIL only)
50719029	Tap-n-go "MD EL" head M10x1,25 LH.F.
50719030	Tap-n-go "MD EL" head M10x1,25 LH.F. (fits HU only)
50719031	Tap-n-go "MD EL" head 3/8"-24 UNF LH.F.
50719032	Tap-n-go "MD EL" head M7x1,00 LH.M.
50719033	Tap-n-go "MD EL" head M10x1,50 LH.F. (fits HU only)
50719038	Tap-n-go "MD EL" head NEUTRAL without adaptor

Generative EAN13 code available.

PACKAGING



NYLON BAG

1 PC. EASYLOAD HEAD
C/W 5 m ROUND NYLON
LINE Ø 2,0 mm AND
OWNER'S MANUAL.

ORDER MULTIPLES OF



40 PCS

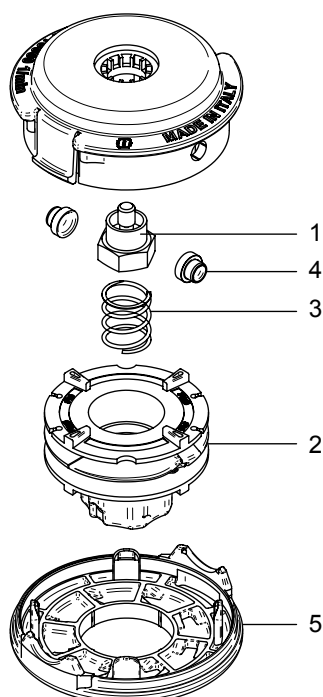

SPARE PARTS

1	I00003000	Adaptor 3/8"-24 UNF LH.F.
	I00003002	Adaptor M8x1,25 LH.M.(fits EMAK only)
	5070011	Adaptor M 8x1,25 LH.F.
	5070008	Adaptor M10x1,25 LH.F.
	5070020	Adaptor M 8x1,25 LH.M.
	5070021	Adaptor M 7x1,00 LH.M.
	5070026	Adaptor M10x1,00 LH.F. (fits STHIL only)
	5070024	Adaptor M10x1,25 LH. F. (fits HU only)
	5070032	Adaptor M10x1,50 LH. F. (fits HU only)
2	K99900054	Spool without line
3	M00200010	Spring
4	B00400005	Line retainer
5	C00205003	Lower cover

EASYLoad

tap-n-go trimmer head Ø130

Double line nylon head Ø130 mm complete with adaptor bolt.



NEW



Ø 130 mm

P/N	DESCRIPTION
50709006	Tap-n-go "HD EL" head M12x1,25 LH.F.(fits XEN only)
50709007	Tap-n-go "HD EL" head M8x1,25 LH.M.(fits EMAK only)
50709008	Tap-n-go "HD EL" head M 8x1,25 LH.F.
50709015	Tap-n-go "HD EL" head M10x1,25 LH.F.
50709033	Tap-n-go "HD EL" head M10x1,25 LH.M.
50709034	Tap-n-go "HD EL" head M12x1,50 LH.F. / M14x1,5 LH.F.
50709005	Tap-n-go "HD EL" head M 8x1,25 LH.M.
50709035	Tap-n-go "HD EL" head M10x1,00 LH.F. (fits STHIL only)
50709036	Tap-n-go "HD EL" head M10x1,50 LH.M.(fits MC only)
50709038	Tap-n-go "HD EL" head M12x1,75 LH F (fits HU only)
50709039	Tap-n-go "HD EL" head M10x1,25 LH F (fits HU only)
50709045	Tap-n-go "HD EL" head M12X1.5 SX F (fits STHIL only)
50709048	Tap-n-go "HD EL" head M10x1,50 LH F (fits HU only)
50709037	Tap-n-go "HD EL" head NEUTRAL without adaptor

Generative EAN13 code available.

PACKAGING



NYLON BAG

1 PC. EASYLOAD HEAD
C/W 5 m ROUND NYLON
LINE Ø 2,4 mm AND
OWNER'S MANUAL.

ORDER MULTIPLES OF



30 PCS

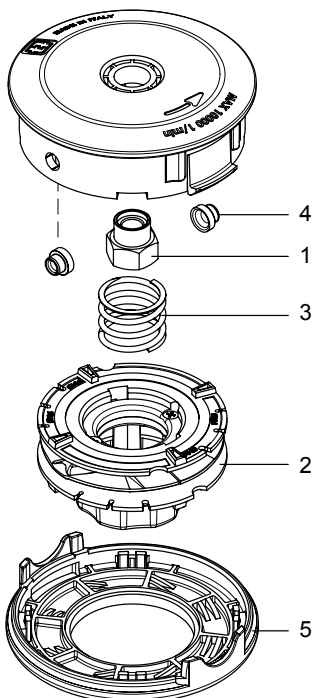

SPARE PARTS

1	I00003001	Adaptor M12x1,25 LH.F. (fits XEN only)
	I00003002	Adaptor M8x1,25 LH.M.(fits EMAK only)
	5070011	Adaptor M 8x1,25 LH.F.
	5070008	Adaptor M10x1,25 LH.F.
	5070009	Adaptor M10x1,25 LH.M.
	5070010	Adaptor M12x1,50 LH.F. (fits STHIL only)
	5070039	Adaptor M14x1,50 LH.F. (fits STHIL only)
	5070020	Adaptor M 8x1,25 LH.M.
	5070026	Adaptor M10x1,00 LH.F. (fits STHIL only)
	5070027	Adaptor M10x1,50 LH.M.(fits MC only)
	5070028	Adaptor M12x1,75 LH. F. (fits HU only)
	5070024	Adaptor M10x1,25 LH. F. (fits HU only)
	5070032	Adaptor M10x1,50 LH. F. (fits HU only)
2	K99900076	Spool without line
3	M00200002	Spring
4	B00400005	Line retainer
5	C00205002	Lower cover

NEW

EASYLoad

tap-n-go trimmer head - universal mounting

Tape-n-go double line head, universal mounting without adaptor, centering bore for both 20÷25.4 mm.
Delivered complete with kit of adaptor washers.



Ø109 > 25 cc
Ø130 > 33 cc



NO BOLT SHAFT



Ø 109 mm



Ø 130 mm

P/N**DESCRIPTION**

50719039 Tap-n-go "MD EL" universal head **Ø109**

50709056 Tap-n-go "HD EL" universal head **Ø130**

Generative EAN13 code available.

PACKAGING

NYLON BAG

1 PC. EASYLOAD HEAD
C/W 5 m ROUND NYLON LINE
AND OWNER'S MANUAL.

ORDER MULTIPLES OF

40 PCS → Ø109
30 PCS → Ø130

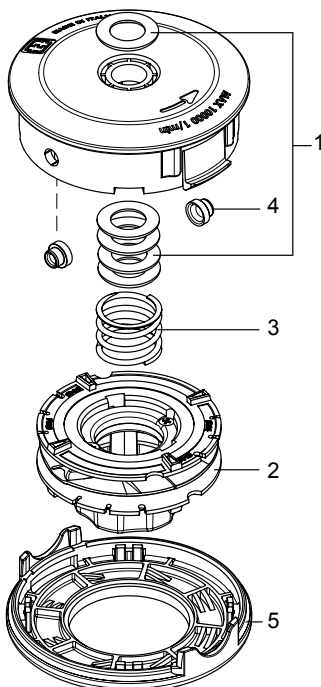
**SPARE PARTS**

1	K00401008	Kit of adaptor washers and reduction rings
2	K99900054	Spool without line - Ø109
	K99900076	Spool without line - Ø130
3	M00200010	Spring - Ø109
	M00200002	Spring - Ø130
4	B00400005	Line retainer
5	C00205003	Lower cover - Ø109
	C00205002	Lower cover - Ø130

Tap-N-Go

trimmer head Ø109

Double line nylon head Ø 109 mm complete with adaptor bolt - Ø 2 mm nylon line.



P/N	DESCRIPTION
50719025	Tap-n-go head M7x1 LH.M.
50719015	Tap-n-go head M8x1.25 LH.M. (fits EMAK only)
50719016	Tap-n-go head M8x1.25 LH.F.
50719017	Tap-n-go head M8x1.25 LH.M.
50719018	Tap-n-go head M10x1.00 LH.F. (fits STIHL only)
50719019	Tap-n-go head M10x1.25 LH.F.
50719020	Tap-n-go head M10x1.25 LH.F. (fits HU only)
50719021	Tap-n-go head M10x1.25 LH.M.
50719022	Tap-n-go head M10x1.50 LH.F. (fits HU only)
50719023	Tap-n-go head 3/8"- 24 LH.F.
50719034	Tap-n-go head M10x1,00 LH.F.
50719035	Tap-n-go head M10x1,50 LH.M. (fits MC only)

PACKAGING

NYLON BAG

ORDER MULTIPLES OF



SPARE PARTS

1	5070021	Adaptor M 7 x 1 Left male
	100003002	Adaptor M 8 x 1.25 Left male (fits EMAK only)
	5070011	Adaptor M 8 x 1.25 Left female
	5070020	Adaptor M 8 x 1.25 Left male
	5070026	Adaptor M 10 x 1.00 Left female (fits STIHL only)
	5070023	Adaptor M 10 x 1.00 Left female
	5070008	Adaptor M 10 x 1.25 Left female
	5070024	Adaptor M 10 x 1.25 Left female (fits HU only)
	5070009	Adaptor M 10 x 1.25 Left male
	5070032	Adaptor M 10 x 1.50 Left female (fits HU only)
	5070027	Adaptor M 10 x 1.50 Left female (fits MC only)
	100003000	Adaptor 3/8"-24 Left female
2	B01201002	Spool without line
3	M00200002	Spring
4	5070005	Line retainer
5	C00205001	Lower cover (until 05/2007) - OLD
	C00205003	Lower cover (from 06/2007) - NEW

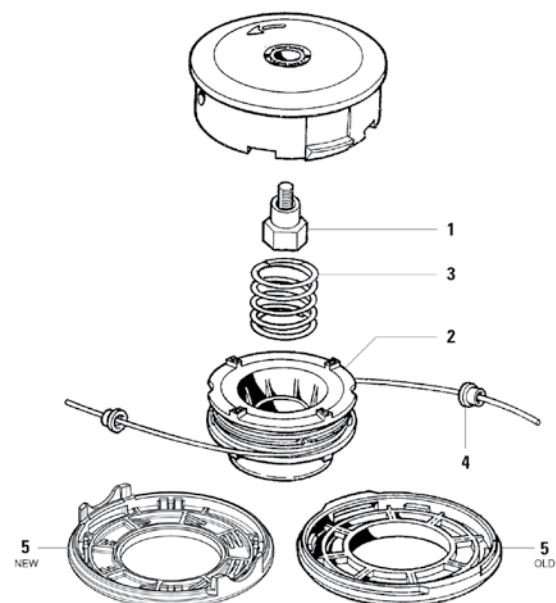

Tap-N-Go

trimmer head Ø130

Double line nylon head Ø 130 mm complete with adaptor bolt
- Ø 2,4 mm nylon line.



P/N	DESCRIPTION
50709010	Tap-n-go head M8x1.25 LH.M. (fits EMAK only)
50709011	Tap-n-go head M8x1.25 LH.F.
50709016	Tap-n-go head M8x1.25 Left male
50709017	Tap-n-go head M10x1.00 LH.F. (fits STIHL only)
50709012	Tap-n-go head M10x1.25 LH.F.
50709022	Tap-n-go head M10x1.25 LH.F. (fits HU only)
50709013	Tap-n-go head M10x1.25 LH.M
50709018	Tap-n-go head M10x1.50 LH.M. (fits MC only)
50709047	Tap-n-go head M10x1.50 LH.F. (fits HU only)
50709009	Tap-n-go head M12x1.25 LH.F. (fits XENOAH only)
50709014	Tap-n-go head M12x1.50 LH.F. + M 14 x 1.50 LHF
50709021	Tap-n-go head M12x1.75 LH.F. (fits HU only)
50709019	Tap-n-go head NEUTRAL delivered without adaptor

PACKAGING

NYLON BAG

ORDER MULTIPLES OF



SPARE PARTS

1	100003002	Adaptor M 8 x 1.25 Left male (fits EMAK only)
	5070011	Adaptor M 8 x 1.25 Left female
	5070020	Adaptor M 8 x 1.25 Left male
	5070044	Adaptor M 8 x 1.25 Right male
	5070026	Adaptor M 10 x 1.00 Left female (fits STIHL only)
	5070008	Adaptor M 10 x 1.25 Left female
	5070024	Adaptor M 10 x 1.25 Left female (fits HU only)
	5070009	Adaptor M 10 x 1.25 Left male
	5070027	Adaptor M 10 x 1.50 Left male (fits MC only)
	5070032	Adaptor M 10 x 1.50 Left female (fits HU only)
	100003001	Adaptor M 12 x 1.25 Left female (fits XENOAH only)
	5070010	Adaptor M 12 x 1.50 Left female
	5070028	Adaptor M 12 x 1.75 Left female (fits HU only)
	5070039	Adaptor M 14 x 1.50 Left female (fits STIHL only)
2	5070003	Spool without line
3	5070004	Spring
4	5070005	Line retainer
5	5070002	Lower cover (until 05/2007) - OLD
	C00205002	Lower cover (from 06/2007) - NEW

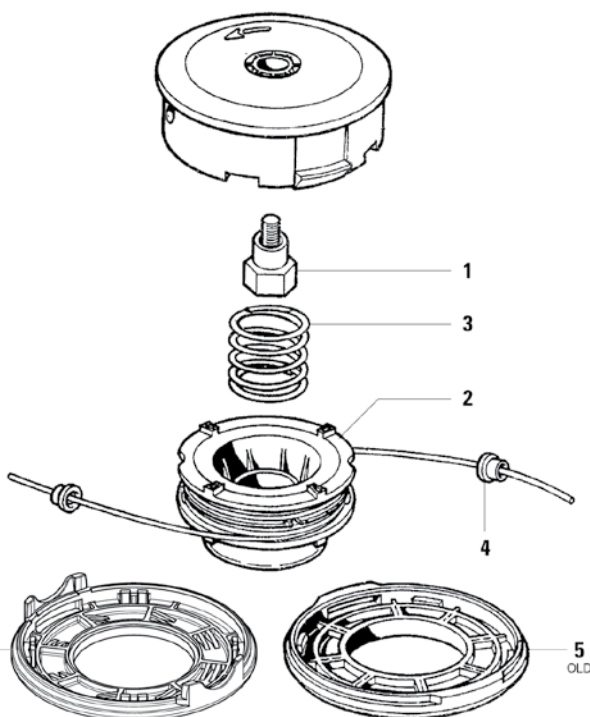

SUPERPro

trimmer head Ø130

Evolution of traditionally top performing Tecomec Tap-n-Go head. Reinforced nylon spool makes this sturdy head most suitable for professional service contractors and landscaping all-day-duty operations.

- Line spool with zinc plated steel insert. Extreme wear resistance.
- 30% higher wrapping capacity than traditional Tecomec Tap-N-Go heads.



>LINE SPOOL INTERCHANGEABLE WITH SPOOL P/N 5070003 OF TRADITIONAL TECOMEK TAP-N-GO HEADS AND ALSO AVAILABLE SEPARATELY. WRAPPING CAPACITY INCREASED +30%!

>ZINC PLATED STEEL INSERT

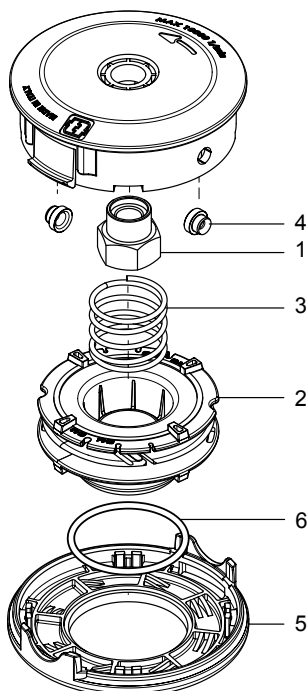

P/N	DESCRIPTION
50769008	Tap-n-go "HD SP" head M12X1.25 SX.F. (fits XENOAH only)
50769000	Tap-n-go "HD SP" head M8 SX.M. (fits EMAK only)
50769001	Tap-n-go "HD SP" head M8 SX F.
50769004	Tap-n-go "HD SP" head M10X1.25 SX.F
50769006	Tap-n-go "HD SP" head M10X1,25 SX.M
50769009	Tap-n-go "HD SP" head M12X1.5/M14X1.5 SX/F
50769002	Tap-n-go "HD SP" head M8 SX.M
50769003	Tap-n-go "HD SP" head M10X1 SX.F. (fits STIHL only)
50769007	Tap-n-go "HD SP" head M10X1,5 SX.M. (fits MC only)
50769010	Tap-n-go "HD SP" head M12X1,75 SX/F (fits HU only)
50769005	Tap-n-go "HD SP" head M10X1,25 SX/F (fits HU only)
50769013	Tap-n-go "HD SP" head M10X1,5 SX/F (fits HU only)
50769011	Tap-n-go "HD SP" head NEUTRAL without adaptor

PACKAGING

NYLON BAG

ORDER MULTIPLES OF



30 PCS

SPARE PARTS

1	I00003002	Adaptor M 8 x 1.25 Left male (fits EMAK only)
	5070011	Adaptor M 8 x 1.25 Left female
	5070020	Adaptor M 8 x 1.25 Left male
	5070044	Adaptor M 8 x 1.25 Right male
	5070026	Adaptor M 10 x 1.00 Left female (fits STIHL only)
	5070008	Adaptor M 10 x 1.25 Left female
	5070024	Adaptor M 10 x 1.25 Left female (fits HU only)
	5070009	Adaptor M 10 x 1.25 Left male
	5070027	Adaptor M 10 x 1.50 Left male (fits MC only)
	5070032	Adaptor M 10 x 1.50 Left female (fits HU only)
	I00003001	Adaptor M 12 x 1.25 Left female (fits XENOAH only)
	5070010	Adaptor M 12 x 1.50 Left female
	5070028	Adaptor M 12 x 1.75 Left female (fits HU only)
	5070039	Adaptor M 14 x 1.50 Left female (fits STIHL only)
2	B01201003	Spool without line
3	M00200005	Spring
4	5070005	Line retainer
5	C00205002	Lower cover
6	G00001052	O-ring

Tap-N-Go

trimmer head Ø160



Double line nylon head Ø160 mm - Ø3 mm nylon line.



P/N	DESCRIPTION
5075901	Tap-n-go head NEUTRAL delivered without adaptor
50759000	Tap-n-go head M12x1.75 LH.F. (fits HU only)
5075902	Tap-n-go head M8x1.25 LH.M. (fits EMAK only)

PACKAGING
NYLON BAG

ORDER MULTIPLES OF
25 PCS

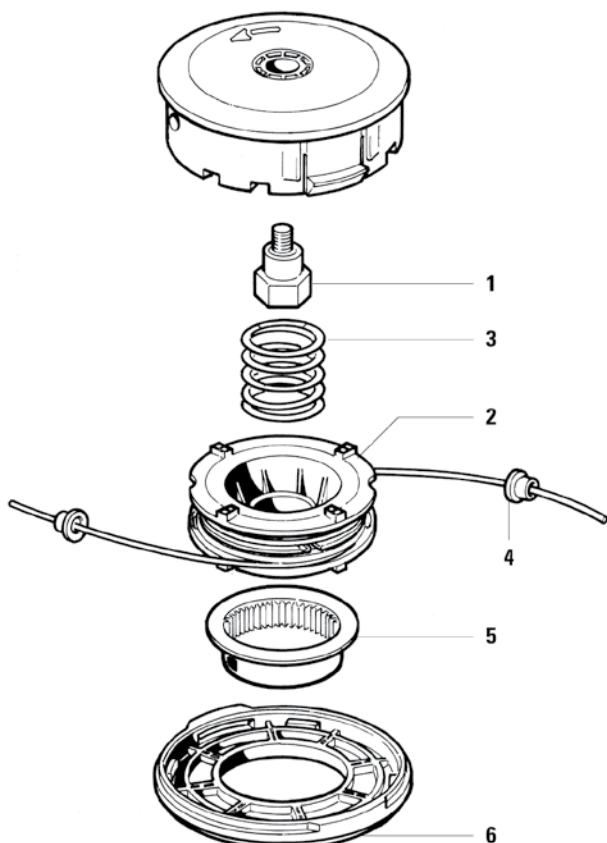

SPARE PARTS		
1	100003002	Adaptor M 8 x 1.25 Left male (fits EMAK only)
	5070011	Adaptor M 8 x 1.25 Left female
	5070020	Adaptor M 8 x 1.25 Left male
	5070026	Adaptor M 10 x 1.00 Left female (fits STIHL only)
	5070008	Adaptor M 10 x 1.25 Left female
	5070009	Adaptor M 10 x 1.25 Left male
	5070024	Adaptor M 10 x 1.25 Left female (fits HU only)
	5070027	Adaptor M 10 x 1.50 Left male (fits MC only)
	5070032	Adaptor M 10 x 1.50 Left female (fits HU only)
	100003001	Adaptor M 12 x 1.25 Left female (fits XEN only)
	5070010	Adaptor M 12 x 1.50 Left female
	5070028	Adaptor M 12 x 1.75 Left female (fits HU only)
	5070039	Adaptor M 14 x 1.50 Left female (fits Stihl only)
2	5075003	Spool without line
3	5075006	Spring
4	5070005	Line retainer
5	5075004	Knob
6	5075002	Lower cover



Tap-N-Go

trimmer head - universal mounting



Semi-automatic head "pro universal". Tape-n-go double line head, universal mounting without adaptor, centering bore for both 20+25.4 mm - Ø 2,4 mm nylon line.
Delivered complete with kit of adaptor washers.



Ø109 > 25 cc
Ø130 > 33 cc



Ø 109 mm



Ø 130 mm

P/N DESCRIPTION

P/N	DESCRIPTION
50719044	Tap-n-go universal head Ø109
5070911	Tap-n-go universal head Ø130

PACKAGING

NYLON BAG

ORDER MULTIPLES OF



40 PCS

SPARE PARTS

1	K00401008	Kit of adaptor washers and reduction rings
2	B01201002	Spool without line - Ø109
	5070003	Spool without line - Ø130
3	M00200002	Spring - Ø109
	5070004	Spring - Ø130
4	5070005	Line retainer
5	C00205003	Lower cover - Ø109
	5070038	Lower cover - Ø130 - OLD
	C00205002	Lower cover - Ø130 - NEW
6	P00400007	Spacer (for Ø109 mm only)

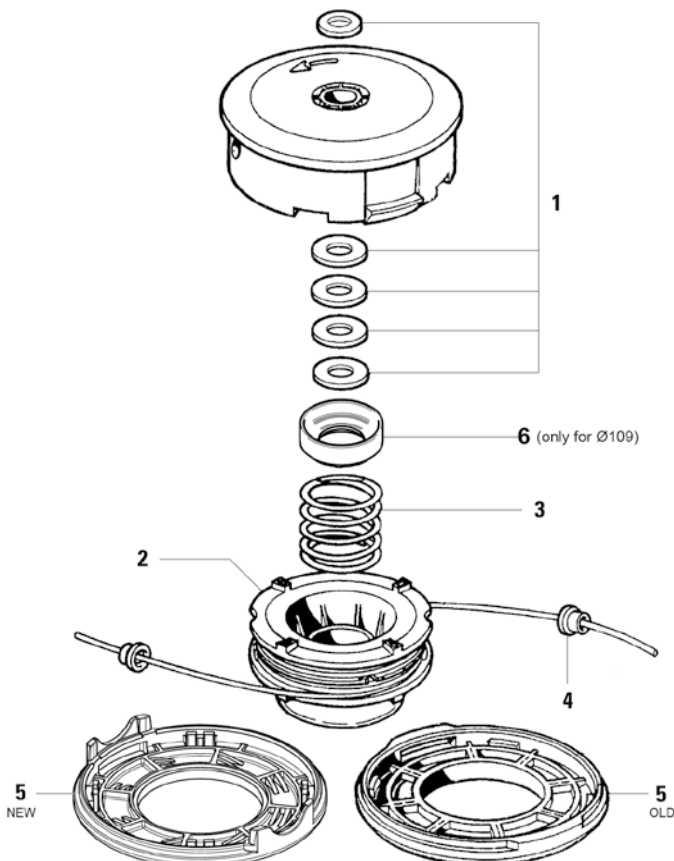

SUPERPro

trimmer head Ø130 - universal mounting



Evolution of traditionally top performing Tecomec Tap-n-Go head. Reinforced nylon spool makes this sturdy head most suitable for professional service contractors and landscaping all-day-duty operations.

Delivered complete with kit of adaptor washers.

- Line spool with zinc plated steel insert. Extreme wear resistance.
- 30% higher wrapping capacity than traditional Tecomec Tap-N-Go heads.



P/N DESCRIPTION

P/N	DESCRIPTION
50769012	Tap-n-go "HD SP" universal head

PACKAGING

NYLON BAG

ORDER MULTIPLES OF



>LINE SPOOL INTERCHANGEABLE WITH SPOOL P/N 5070003 OF TRADITIONAL TECOME C TAP-N -GO HEADS AND ALSO AVAILABLE SEPARATELY. WRAPPING CAPACITY INCREASED +30%!



>ZINC PLATED STEEL INSERT

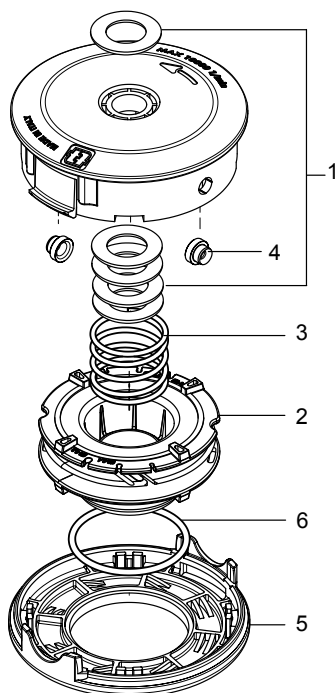

SPARE PARTS

1	K00401008	Kit of adaptor washers and reduction rings
2	B01201003	Spool without line
3	M00200005	Spring
4	5070005	Line retainer
5	C00205002	Lower cover
6	G00001052	O-ring

MINITap-N-Go

trimmer head

Any Trimmer Head is supplied single packed in a nice clamshell for Wall Display Package.

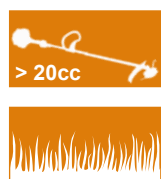

PACKAGING



CLAMSHELL

ORDER MULTIPLES OF



40 PCS



P/N

DESCRIPTION

50909001

suitable to: **Homelite** DA03001 / Da03001
A Dual line head with 5/16" Bump knob fits ST155, ST165, ST285 and more.
Also Black & Dekker



P/N

DESCRIPTION

50909003

suitable to: **RYOBI** 153577 Dual line head with 5/16" Bump knob. Fits 700R, 710R, 720R, 740R, 75R, 760R, 765R, 766R, 770R, 920R, 970R, CS720R, SS720R and more.



P/N

DESCRIPTION

50909004

suitable to: **McCulloch** two line bump feed with 1/4" Bump knob. Fits Promac, MK1, MK2 & MK3.

PROType

manual head



Double line nylon head complete with adaptor bolt, aluminium knob - Ø 2,4 mm nylon line.



P/N DESCRIPTION

P/N	DESCRIPTION
5030901	Head M7x1.00 LH.M.
5030903	Head M8x1.25 LH.M.
5030904	Head M8x1.25 LH.M. (fits EMAK only)
5030907	Head M8x1.25 LH.F.
5030911	Head M10x1.00 LH.F. (fits HU only)
5030910	Head M10x1.00 LH.F. (fits Stihl only)
5030913	Head M10x1.25 LH.F.
5030914	Head M10x1.25 LH.M.
5030915	Head M10x1.50 LH.F.
5030917	Head M12x1.50 LH.F. (fits Stihl only)
5030918	Head M12x1.75 LH.F. (fits HU only)

PACKAGING

NYLON BAG

ORDER MULTIPLES OF

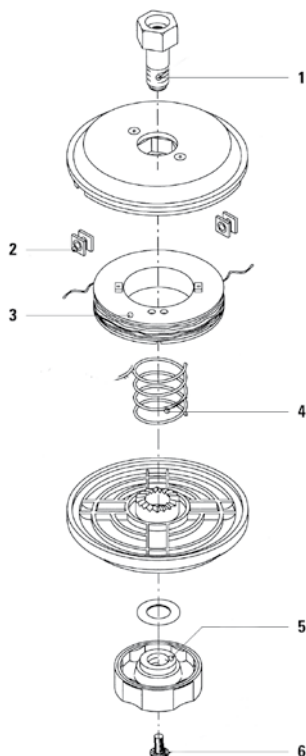
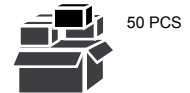

SPARE PARTS

1	5030015	Adaptor M 7 x 1.00 Left male
	5030018	Adaptor M 8 x 1.25 Left male
	5030044	Adaptor M 8 x 1.25 Left male (fits EMAK only)
	5030021	Adaptor M 8 x 1.25 Left female
	5030025	Adaptor M 10 x 1.00 Left female (fits HU only)
	5030024	Adaptor M 10 x 1.00 Left female (fits Stihl only)
	5030027	Adaptor M 10 x 1.25 Left female
	5030028	Adaptor M 10 x 1.25 Left male
	5030029	Adaptor M 10 x 1.50 Left female
	5030031	Adaptor M 12 x 1.50 Left female
	5030032	Adaptor M 12 x 1.75 Left female
2	5030011	Line retainer (square)
3	5030014	Spool without line
	5030043	Spool with line (6m)
4	5030010	Spool spring
5	5030009	Left knob
	5030013	Right knob
6	5030012	Knob screw



Guide list for nylon head adaptors



ALKO	LT250C	8 x 1.25 LHM
	MS400, 106146	10 x 1.25 LHF
	106389, 106144, 106436, 106145	8 x 1.25 LHF
ARIMITSU	ACC15, ACC17, ACD-17, ACD18, ACE30, ACZEK, AM-16D, AM-24, AM-24D, AM-31, AM-31K, AM-31KL, AM40, AM50	8 x 1.25 LHM
ALPINA	170, 180, 190, 200	8 x 1.25 LHM
	VIP21, VIP25, VIP30, VIP34, VIP34D, VIP34F, VIP42, VIP35F, VIP52, VIP52D, VIP52F, VIP42D, VIP42F	8 x 1.25 LHF
	210, 220	10 x 1.25 LHF
BLUEBIRD	SBC23E, 27E, NBC31EA, NBC38E, M47, M54	10 x 1.00 LHF
DOLMAR	BC250, LT250, BC330, BC400, SD330, BC250, PRO370, PRO400, MS3300/4000/4500	10 x 1.25 LHM
	BC337, BC377, NB26, NB03, NB04, NB31, NB40, MS3500, NB40, NB411, NB50, NB351, BD330, C250, LT-250	10 x 1.00 LHF
	BC225, C225, LT225, MS220, MS2300, MS2600, MS3100, LT154, NB, NB01F, NB02, NB16F, NB211, NBF171, NB26/31, LT225, LT255, NB2, NB271, MS-250, MS3200, MS5200, MS2810	8 x 1.25 LHF
	MS340, BC-12, BC-210, BC-212, MS5250, BC210, BC212, MS-30C, MS30U	10 x 1.25 LHF
	MS3300, MS4000, MS4500, MS3310, MS-4010, MS-4510	12 x 1.50 LHF
	NB231AU, NB231A, NB23F, NB171, LT250	8 x 1.25 RHF
	LT210	10 x 1.25 RHF
ECHO	SRM2300L, 2300U, SRM2090L, 2090U, SRM250EL, ARM400A, RM460, RMA2530, SRA2190, 250EU, SRM310, 310U, RM380, SRM302BDX, SRM3800, SRM4600, SRM2450L, 2450U, SRM3500, SRM3550, SRM2510, RM460, SRA2190, RMA2530, SRM2600L, 2600U, SRM3150L, 3150U, SRM343SL, CLS4600, GT2400, RM310, SRM2010L, 140, 160AE, 190, 200, 200BE, 250/EU, 300, 302, 310/U, 400, 402, 500, 501, 3150U, 3800, 4600, SRM300, RMA2530, SRM140DA, SRM1500, SRM1501, SRM200BE, SRM200CE, SRM200DA, SRM200DB, SRM2010, SRM2200, SRM2201, SRM2301, SRM2500, SRM2501, SRM2502, SRM3000, SRM3001, SRM300AE, SRM300E, SRM3010, SRM400AE, SRM400BE, SRM402DE, SRM3800, 2010, 2300, 2090, 2090U, 2510, 3500, 2190, 2530, SRM-2450L, 2500, 2501, 2502, 250EL, 2510, 2600L, 3010, SRM-2455, 2015, 2455, 315SL, 360, 2655, 400, 5000	10 x 1.25 LHF
	ST160AE, 500, 501, 210AE, 2300/U, 2450U, 2510, 2530, 2600U	10 x 1.25 RHF
	CLS4600, CLS5800, CLS5810	12 x 1.75 LHF
	200 Series -200, 2201C, 260/D, 2601C, 2601CVA, 261/A, 300 Series 300A/AIC, 301, 310, 350, 400 Series 400/AIC, 400A, 410, 450, 460/AVS, 8060, 8100, 8200, 8250R, STARK26TR	8 x 1.25 LHM
	8250RL, 8220IC, 8260IC, STARK26IC, 8250/IC/ICD, 8300NEW, 8250ICD, 8250ICNEW, 8350/IC, 8400/IC, 8460/IC, 8530/IC, 8550BOSS, 8355, 8405, 8465, 8535	8 x 1.25 LHM
HOMELITE	TM523	7 x 1.00 LHM
	BCH - 20, 24 2D, 32C, 33, 33B, 33DI, 33TO	8 x 1.25 LHM
	HBC30, -30B, 38, 40, HK- 14, 18, 24, 28, 33, 38, PCB3600, 3600E, PLT3400, ST155, 175C, 185C, 285C, 385C, ST485, ST485C	8 x 1.25 LHF
	ST360, ST385, SXD20, TK518, NBA524, PMB522, TXD508	8 x 1.25 LHM
	BCH38, BCH40, BCH48, PBC3800, PBC4000	10 x 1.25 LHF
	NBA524, PMB522, TXD508	10 x 1.25 LHM
HONDA	UH41, SXD-25HE	8 x 1.25 LHM
	UMK422LTE/UT4E/LT4E	10 x 1.25 LHF
HUSQVARNA	24R (before 1987)	7 x 1.00 LHM
	265RX, 250RX, 245RX, 135R, 132RD, 132LD, 125R, 25R, 125RD, 125LD, 125RB, 132RL, 245R, 125L, 132L, 125RJ, 125RJD, 26R, 235R, 32L, 120L, 225L, 225LD, 227R	12 x 1.75 LHM
	232L, 232LCAT, 32R, 225RJ, 225R, RD, 232R, 232RCAT, 322L, 325LX/XT, 325RJX, 322RJ, 325RX/RXT	10 x 1.25 LHF
	235RCAT, 240R, 240RBD, 250RX, 245R, 245RX, 265RX, 140R, 165R, 244R, 244GX, 36R, 39R, 16R, 18RL, 22RL, 240RJ, 142RB, 152RB, 252RX	12 x 1.75 LHF
	Mondo MEGA, Mondo Maxi	3/8" x .24 LHF
	26L	3/8" x .24 RHF
	16R, 25R - before 1987	8 x 1.25 LHM

Guide list for nylon head adaptors



ISEKI SHINDAIWA	DYB251, DYB252, DYB254, DYB261, DYB262, DYB321, DYB322	8 x 1.25 LHM
	DYB351, DYB453, DYB354, DYB454	10 x 1.25 LHM
	DYB201, DYB202, DYB231, DYB232	7 x 1.00 LHM
	IAX180, 190, 250, 350, 400, 500	8 x 1.25 LHF
JONSERED	G25RD	8 x 1.25 LHF
	GR32L/CAT, GR44, GT21/22/24, RS44, BP2040C, GR3032D/L	10 x 1.25 LHF
	GR32D/CAT, GR36/CAT, GR41/50, R38/45, RS30/38/40/45, RS51PRO, RS52, GR2036, BP2052, BP240C	12 x 1.75 LHF
	G25RD	8 x 1.25 LHF
KAAZ	V20	7 x 1.00 LHM
	K10, K20, K2020, K2Q, K2Q20, K30, KLQ, KOP20B, KPQ/20, KQ, KQP20, KQT130, KT12, RQ20, U10, V15/18/25, VP15/20, VS220/230/250, VX230/260	8 x 1.25 LHF
	KQ20, V10	8 x 1.25 RHF
	410, J40/BD/HD, J400/GX, JLKT200, JLQT200, JQ/40/50, JQG4K, K40D/BD, KQ30/NE, KT10, KT18/1S/30, KW30NE, K40D/BD, KQ30/NE, KT10/18/1S/30, KW30NE, RQ30/40, RX350/351L, TI70,240/410, V190/35/40, V420/520, VNX540, VRX360/440/540, VX221/251C/360/360S, VX440	10 x 1.25 LHF
MC CULLO-CH	BP30AV, DELTA, MS33/40, S'MAC30AV, TD2400/3300/4000	8 x 1.25 LHM
	MAC22/23/30/38	8 x 1.25 LHF
	MAC17/25	8 x 1.25 RHF
	100A, 90/A, 95A, 99A, EB3, MAC80/90/95A, PS1/2/3/4/5, SEB4, SM100, SMAC30AV, SMAV38AV	10 x 1.25 LHF
	TD2100, MAC32, MAC37	10 x 1.25 LHM
	MAC60A, MAC80A	10 x 1.25 RHF
	SUPERMAC26, MAC30A, 30AV, PRATER30, EUROPA92/35A, EUROPA, MS24, MS52, PROMAC38AV, BP38AV, WINDSORKIT26, VERSAILLES38, BP26AV, BP35AV	10 x 1.50 LHM
	MAC85A, MAC90A, MAC95A, SMAC30AV, SMAC38AV	10 x 1.25 LHF
MAKITA	RBC230, RBC260, RBC310, RBC410, RBK410, RBC525	8 x 1.25 LHM
	DBC3300, DBC4000, DBC4000C	12 x 1.50 LHF
MARUNAKA	BC180/181DX, BC200/240DX, TM2/21/24DX/F3L	8 x 1.25 LHF
	BT181DX	8 x 1.25 RHF
	G13K	10 x 1.25 LHF
	BC480DX, G3/5, GL3K, T240DX/F53/L	10 x 1.25 LHM
	TM33DX/F43L, TM33DX/F43, T200DX/F43L, T200DX/F43, TM33JX,/F404L, T200JX/F404L, BC330DX, BC400DX, BK404FX	10 x 1.50 LHF
MARUYAMA	BC184/C, BC220DE, BC230/241/326/330/402/480, BC331BK, MB100/250/300/400/500	8 x 1.25 LHM
	32, 35	10 x 1.25 LHM
	23	10 x 1.50 LHF
	BC200C, BC260/H, MC260/S	10 x 1.25 LHF
OLEOMAC	TR60E, TR101E, 720, SPARTA26TR, 725B,	8 x 1.25 LHF
	725BL, 722/726S, SPARTA26S, SPARTA26, 725S/T/D, 730S/T, 735S/T, 740S/T, 746S/T, 733S/T, 755MASTER, 435/440/446/453BP	8 x 1.25 LHM
PARTNER	B400	10 x 1.00 LHF
	200, 203, 205, B250C, B250V(before1987), T250, B323, B325	10 x 1.25 LHF
	B370, B380, B180, B440, B450, B405, B250C/V, B250U, B450G, B450/C, B265J, B405	12 x 1.75 LHF
	T221, T321, B322	8 x 1.00 LHF
POULAN	150, 200, 2620, 800, 900	10 x 1,50 LHF
ROBIN	NB30K, NBR30/40	8 x 1.25 LHM
	IVBK411, NB02, NB16F, NB211, NB26, NB281A, NB31/AU, NB351, NBA231, NBK411, NBT415, IVBF231, NB231, NB23F, NBF171, NBF231	8 x 1.25 LHF
	IVB50L, NB03/4, NB411L, NB50L	10 x 1.00 LHF

Guide list for nylon head adaptors



RYOBI	180KS/S, 3318, REK285BP	8 x 1.25 LHM
	RD1605, RD2414, RD3818	8 x 1.25 LHF
	RD5224, RD5225, RSB2801, RSH1100	10 x 1.25 LHM
	RD260	10 x 1.50 LHF
	RD330, RD430, RD520	12 x 1.75 LHF
SHINDAIWA	C20/230, LT18/20, T18/20/A, T230/XR, T23E, T35	7 x 1.00 LHM
	BP35/45, C23/25/27, C250, F20, R2025/35F, T25/27/250, T260/270/350, YARDWARE220	8 x 1.25 LHM
	B35/40/45, BP35, C35, RC35/45, F18	10 x 1.25 LHM
STIHL	FS50, FS51, FS60, FS61, FS65, FS80E, FS90AVE	8 x 1.25 LHM
	FS44, FS52, FS56, FS66, FS86, FR106, FS74, FS74R, FE55, FS36, FS88, FR108, FS40, FS76, FS76R, FS106, FS108, FS48, FS52, FS62, FS81, FS96,	10 x 1.00 LHF
	FS160, FS220, FS55/R, FS25-4/R, FS65-4/R, FS80R, FS85/R/RT	10 x 1.50 LHF
	420, FS08, FS150/180, FS20, FS200, FS280/K, FS353AV, FS360, FS410, FS420, FR350/450, FS350/450/400K/450K, FS400/L, FS500, FS550	12 x 1.50 LHF
SOLO	FS125, S200, S300	8 x 1.25 LHF
	123, 125, Multimot	10 x 1.00 LHF
	100, 130S, 014, 119, 400, FS135, FS136, S100, S400	10 x 1.25 LHF
	115, 118	10 x 1.25 RHF
	124, 126, 127, 128, 130, 134, 137, 140, 141	12 x 1.50 LHF
TAS TANAKA	AST250/5000/7000, SUM250, SUM301/321/321E/351/400, SUM421/500/7000, TBC16/160/162/20/2000, SUM205/215/220/2200, TBC225-255, TCB23/232/2507250DH/262/265/265SDH/262, TBC265, TBC265SDH/30/300/322/355/37/373/4000/422/422BDH, TBC4500/500/5000/500DH/501/202, TBC300SDH/355DH, TST218, TUM220, TUM250	8 x 1.25 LHM
	SUM3	10 x 1.25 LHF
	TBC16, AST5000, TBC5000, TBC4000	8 x 1.25 RHF
ZENOAH	BC220DL, BC221DL, BC17, BC23, BC32	7 x 1.00 LHM
	BC2300DL	8 x 1.00 LHF
	BC254A, BC260DM/DUM, BC260DM, BC340DWM/FW, BC341DWH, BC431DWM, BC432FWM, BCD20, BCF01, BK345FL, BK435FL, BK530DL	8 x 1.25 LHM
	BC431FWM, BC531DWM, BC532DWM, BK531DL, FBC22, FBC26	10 x 1.25 LHM

TRIMMERLine

ROUND Nylon Line



TYPE



QUALITY



Set of 50 nylon whips, 200 mm (8") long.

P/N	DESCRIPTION
05200038	Ø 2.4 mm (.095")
05200039	Ø 2.7 mm (.105")
05200040	Ø 3.0 mm (.118")
05200041	Ø 3.3 mm (.130")

PACKAGING

NYLON BAG

ORDER MULTIPLES OF



50 PCS



Donut 15m

P/N	DESCRIPTION	PACKAGING	
5200143	Ø 1.3 mm 15 m (.050")		196 PCS.
5200144	Ø 1.6 mm 15 m (.065")		196 PCS.
5200145	Ø 2.0 mm 15 m (.080")		196 PCS.
5200146	Ø 2.4 mm 15 m (.095")	CLAMSHELL	182 PCS.
5200147	Ø 2.7 mm 15 m (.105")		112 PCS.
5200148	Ø 3.0 mm 15 m (.119")		112 PCS.
5200149	Ø 3.3 mm 15 m (.130")		112 PCS.

TRIMMERLine

ROUND Nylon Line



TYPE



QUALITY



Donut

P/N	DESCRIPTION
5200168	Ø 1.6 mm 97 m (.065")
5200169	Ø 2.0 mm 63 m (.080")
5200170	Ø 2.4 mm 44 m (.095")
5200171	Ø 2.7 mm 36 m (.105")

PACKAGING

CLAMSHEEL

ORDER MULTIPLES OF



72 PCS

Donut

P/N	DESCRIPTION
5200031	Ø 1.6 mm 196 m (.065")
5200014	Ø 2.0 mm 126 m (.080")
5200015	Ø 2.4 mm 88 m (.095")
5200132	Ø 2.7 mm 72 m (.105")
5200016	Ø 3.0 mm 56 m (.119")
5200017	Ø 3.3 mm 46 m (.130")

PACKAGING

CLAMSHEEL

ORDER MULTIPLES OF



40 PCS

TRIMMERLine

ROUND Nylon Line

TYPE



QUALITY



Spool 2 pounds
(0,904 Kg)

P/N	DESCRIPTION
5200072	Ø 1.3 mm 565 m (.050")
5200073	Ø 1.6 mm 393 m (.065")
5200074	Ø 2.0 mm 251 m (.080")
5200075	Ø 2.4 mm 175 m (.095")
5200076	Ø 2.7 mm 143 m (.105")
5200077	Ø 3.0 mm 112 m (.119")
5200078	Ø 3.3 mm 92 m (.130")
05200140	Ø 3.5 mm 82.4 m (.138")
05200142	Ø 4.0 mm 63.4 m (.157")



Spool 3 pounds
(1.356 Kg)

P/N	DESCRIPTION
5200191	Ø 2.0 mm 379 m (.080")
5200192	Ø 2.4 mm 264 m (.095")
5200193	Ø 2.7 mm 216 m (.105")
5200236	Ø 3.0 mm 169 m (.119")
5200194	Ø 3.3 mm 139 m (.130")

Spool 4 pounds
(1.814 Kg)

P/N	DESCRIPTION
5200070	Ø 2.0 mm 503 m (.080")
5200046	Ø 2.4 mm 349 m (.095")
5200071	Ø 2.7 mm 286 m (.105")
5200047	Ø 3.0 mm 223 m (.119")
5200048	Ø 3.3 mm 185 m (.130")
05200141	Ø 3.5 mm 164.9 m (.138")
05200143	Ø 4.0 mm 126.8 m (.157")

Spool 5 pounds
(2.268 Kg)

P/N	DESCRIPTION
5200195	Ø 2.0 mm 629 m (.080")
5200196	Ø 2.4 mm 439 m (.095")
5200197	Ø 2.7 mm 360 m (.105")
5200238	Ø 3.0 mm 281 m (.119")
5200198	Ø 3.3 mm 232 m (.130")



Spool 10 Kg

P/N	DESCRIPTION
5200064	Ø 1.3 mm (.050")
5200065	Ø 1.6 mm (.065")
5200066	Ø 2.0 mm (.080")
5200003	Ø 2.4 mm (.095")
5200067	Ø 2.7 mm (.105")
5200004	Ø 3.0 mm (.119")
5200005	Ø 3.3 mm (.130")

P. N. AND PRICES ARE REFERRED TO 1 KG

TRIMMERLine

SQUARE Nylon Line

TYPE



QUALITY



Set of 50 nylon whips, 300 mm (12") long.

P/N	DESCRIPTION
-----	-------------

5200040	☒ 3.0 mm (.119")
---------	------------------

5200041	☒ 3.3 mm (.130")
---------	------------------

PACKAGING

NYLON BAG

ORDER MULTIPLES OF



150 PCS



Set of 50 nylon whips, 300 mm (12") long.

P/N	DESCRIPTION
-----	-------------

05200035	☒ 3.0 mm (.119")
----------	------------------

05200036	☒ 3.3 mm (.130")
----------	------------------

PACKAGING

CLAMSHELL

ORDER MULTIPLES OF



60 PCS

TRIMMERLine

SQUARE Nylon Line



TYPE



QUALITY



Donut 15m

P/N	DESCRIPTION	PACKAGING	
5200150	∅ 2.4 mm (.095")	CLAMSHEEL	168 PCS.
5200151	∅ 2.7 mm (.105")		112 PCS.
5200152	∅ 3.0 mm (.119")		112 PCS.
5200153	∅ 3.3 mm (.130")		112 PCS.

Donut

P/N	DESCRIPTION
5200174	∅ 2.4 mm 34 m (.095")
5200175	∅ 2.7 mm 28 m (.105")
5200176	∅ 3.0 mm 22 m (.119")
5200177	∅ 3.3 mm 18 m (.130")

PACKAGING

CLAMSHEEL

ORDER MULTIPLES OF

72 PCS



Donut

P/N	DESCRIPTION
5200062	∅ 2.4 mm 69 m (.095")
5200118	∅ 2.7 mm 57 m (.105")
5200035	∅ 3.0 mm 44 m (.119")
5200036	∅ 3.3 mm 36 m (.130")

PACKAGING

CLAMSHEEL

ORDER MULTIPLES OF

40 PCS



TRIMMERLine

SQUARE Nylon Line

TYPE



QUALITY



Spool 2 pounds
(0.904 Kg)

P/N	DESCRIPTION
5200081	∅ 2.4 mm 137 m (.095")
5200115	∅ 2.7 mm 112 m (.105")
5200082	∅ 3.0 mm 88 m (.119")
5200083	∅ 3.3 mm 72 m (.130")
05200136	∅ 3.5 mm 65.2 m (.138")
05200138	∅ 4.0 mm 49.8 m (.157")



Spool 4 pounds
(1.808 Kg)

P/N	DESCRIPTION
5200080	∅ 2.4 mm 274 m (.095")
5200085	∅ 2.7 mm 225 m (.105")
5200049	∅ 3.0 mm 175 m (.119")
5200050	∅ 3.3 mm 145 m (.130")
05200137	∅ 3.5 mm 130.5 m (.138")
05200139	∅ 4.0 mm 99,7 m (.157")

Spool 5 pounds
(2.260 Kg)

P/N	DESCRIPTION
05200144	∅ 2.7 mm 271,8 m (.105")
5200239	∅ 3.0 mm 221 m (.119")
05200145	∅ 3.3 mm 183,5 m (.130")



Spool 10 Kg

P/N	DESCRIPTION
5200079	∅ 2.4 mm (.095")
5200084	∅ 2.7 mm (.105")
5200037	∅ 3.0 mm (.119")
5200038	∅ 3.3 mm (.130")

P. N. AND PRICES ARE REFERRED TO 1 KG

PERFORMLine

ROUND Nylon Line



TYPE



HIGH DURABILITY

QUALITY



PERFORM LINE is a new concept of high performance professional line with a co-polyamide CORE that guarantees the high durability while the anti weld SKIN is abrasion and notch resistant, with a melting point at 280°C.



Donut

P/N	DESCRIPTION
05200089	Ø 2.5 mm 81 m (.099")
05200090	Ø 3.0 mm 56 m (.119")
05200091	Ø 3.5 mm 41 m (.138")

PACKAGING

CLAMSHELL

ORDER MULTIPLES OF



40 PCS



Spool 3 pounds (1.356 Kg)

P/N	DESCRIPTION
05200092	Ø 2.5 mm 243 m (.099")
05200093	Ø 3.0 mm 169 m (.119")
05200094	Ø 3.5 mm 124 m (.138")

Spool 5 pounds (2.268 Kg)

P/N	DESCRIPTION
05200095	Ø 2.5 mm 405 m (.099")
05200096	Ø 3.0 mm 281 m (.119")
05200097	Ø 3.5 mm 207 m (.138")

SMARTLine

HELICOIDAL Nylon Line

TYPE



LOW
NOISE

QUALITY



SMART LINE is a premium quality low noise monofilament, it keeps the full features of the "TRIMMER LINE" with two more:

- additional low noise (below 100 dB at 5.500 RPM).
- low petrol/electricity consumption (approx. 20%).



Donut 15m

P/N	DESCRIPTION	PACKAGING	
05200079	Ø 1.6 mm 15m (.065")		196 PCS.
05200080	Ø 2.0 mm 15m (.080")		196 PCS.
05200081	Ø 2.4 mm 15m (.095")	CLAMSHEEL	182 PCS.
05200082	Ø 2.7 mm 15m (.105")		112 PCS.
05200083	Ø 3.0 mm 15m (.119")		112 PCS.



Donut

P/N	DESCRIPTION
05200084	Ø 1.6 mm 194m (.065")
05200085	Ø 2.0 mm 126m (.080")
05200086	Ø 2.4 mm 88m (.095")
05200087	Ø 2.7 mm 72m (.105")
05200088	Ø 3.0 mm 56m (.119")

PACKAGING

CLAMSHEEL

ORDER MULTIPLES OF



40 PCS



Spool

P/N	DESCRIPTION
05200132	Ø 2.4 mm 264m (.095")
05200133	Ø 2.7 mm 208m (.105")
05200134	Ø 3.0 mm 169m (.119")

PROTrim

Disk



Universal disk with three (3) nylon blades, cutting diameter 230 ÷ 300 mm, universal mounting without adaptor, centering hole for both 20 ÷ 25.4 mm. Delivered complete with kit of adaptor washers.

P/N	DESCRIPTION
5025901	Pro-trim disk universal mounting - Cutting Ø 230mm
5020937	Pro-trim disk universal mounting - Cutting Ø 300mm

PACKAGING	ORDER MULTIPLES OF
NYLON BAG	40 PCS

P/N	DESCRIPTION
5020909	Pro-trim disk without adaptor - Cutting Ø 255mm
5020919	Pro-trim disk without adaptor - Cutting Ø 300mm

PACKAGING	ORDER MULTIPLES OF
CARTON	40 PCS

SPARE PARTS		
1	5020016	Nylon blade-short - L=67,5mm (cutting Ø230 mm)
	5020017	Nylon blade-long - L=90mm (cutting Ø300 mm)
2	5025011	Complete pin and nut
3	K00401008	Kit of adaptor washers and reduction rings
4	I00003002	Adaptor M 8 x 1.25 Left male (fits EMAK only)
	5070011	Adaptor M 8 x 1.25 Left female
	5070020	Adaptor M 8 x 1.25 Left male
	5070044	Adaptor M 8 x 1.25 Right male
	5070026	Adaptor M 10 x 1.00 Left female (fits STIHL only)
	5070008	Adaptor M 10 x 1.25 Left female
	5070024	Adaptor M 10 x 1.25 Left female (fits HU only)
	5070009	Adaptor M 10 x 1.25 Left male
	5070027	Adaptor M 10 x 1.50 Left male (fits MC only)
	5070032	Adaptor M 10 x 1.50 Left female (fits HU only)
	I00003001	Adaptor M 12 x 1.25 Left female (fits XENOAH only)
	5070010	Adaptor M 12 x 1.50 Left female
	5070028	Adaptor M 12 x 1.75 Left female (fits HU only)
	5070039	Adaptor M 14 x 1.50 Left female (fits STIHL only)

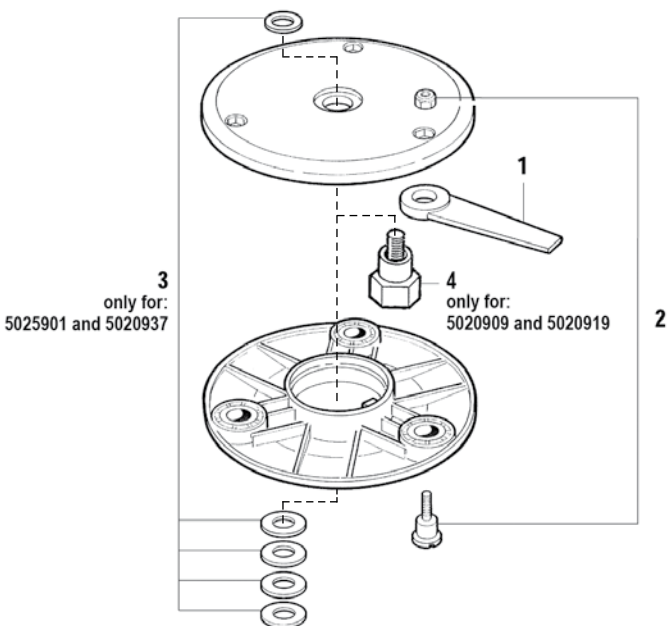

Nylon Blades



3 teeth-Nylon.

P/N	DESCRIPTION		
5010013	outside diam.	250 mm	9,8" inch.
	hole diam.	25,4 mm	1" inch.
PACKAGING		ORDER MULTIPLES OF	
CARTON			



4 teeth-Nylon.

P/N	DESCRIPTION		
5010004	outside diam.	230 mm	9" inch.
	hole diam.	25,4 mm	1" inch.
5010005	outside diam.	255 mm	10" inch.
	hole diam.	25,4 mm	1" inch.
PACKAGING		ORDER MULTIPLES OF	
CARTON		 50 PCS	



8 teeth-Nylon.

P/N	DESCRIPTION		
5010002	outside diam.	220 mm	9" inch.
	hole diam.	25,4 mm	1" inch.
PACKAGING		ORDER MULTIPLES OF	
CARTON		 50 PCS	

Steel Blades



NEW



2 teeth.

P/N	DESCRIPTION		
5001034	outside diam.	300 mm	11,8" inch.
	hole diam.	20,0 mm	.78" inch.
	thickness	3,0 mm	
5001033	outside diam.	300 mm	11,8" inch.
	hole diam.	25,4 mm	1" inch.
	thickness	3,0 mm	

PACKAGING

CARTON

ORDER MULTIPLES OF



50 PCS



2 teeth.

P/N	DESCRIPTION		
5001002	outside diam.	255 mm	10" inch.
	hole diam.	25,4 mm	1" inch.
	thickness	1,6 mm	
5001003	outside diam.	305 mm	12" inch.
	hole diam.	25,4 mm	1" inch.
	thickness	1,6 mm	

PACKAGING

CARTON

ORDER MULTIPLES OF



50 PCS



NEW



3 teeth.

P/N	DESCRIPTION		
05001008	outside diam.	250 mm	9.8" inch.
	hole diam.	25,4 mm	1" inch.
	thickness	2,0 mm	

PACKAGING

CARTON

ORDER MULTIPLES OF



50 PCS

Steel Blades



3 teeth.

P/N	DESCRIPTION		
5001004	outside diam.	230 mm	9" inch.
	hole diam.	25,4 mm	1" inch.
	thickness	1,4 mm	
5001005	outside diam.	255 mm	10" inch.
	hole diam.	25,4 mm	1" inch.
	thickness	1,4 mm	

PACKAGING

CARTON

ORDER MULTIPLES OF



50 PCS



4 teeth.

P/N	DESCRIPTION		
5001007	outside diam.	230 mm	9" inch.
	hole diam.	25,4 mm	1" inch.
	thickness	1,4 mm	
5001008	outside diam.	255 mm	10" inch.
	hole diam.	25,4 mm	1" inch.
	thickness	1,4 mm	

PACKAGING

CARTON

ORDER MULTIPLES OF



50 PCS



8 teeth.

P/N	DESCRIPTION		
5001010	outside diam.	230 mm	9" inch.
	hole diam.	25,4 mm	1" inch.
	thickness	1,4 mm	
5001011	outside diam.	255 mm	10" inch.
	hole diam.	25,4 mm	1" inch.
	thickness	1,4 mm	
5001037	outside diam.	230 mm	9" inch.
	hole diam.	20 mm	.78" inch.
	thickness	1,4 mm	
5001038	outside diam.	255 mm	10" inch.
	hole diam.	20 mm	.78" inch.
	thickness	1,4 mm	

PACKAGING

CARTON

ORDER MULTIPLES OF



50 PCS

Steel Blades



2 teeth-mulching purpose bent blades.

P/N	DESCRIPTION		
5001029	outside diam.	305 mm	12" inch.
	hole diam.	20 mm	.78"inch.
	thickness	4,0 mm	
5001028	outside diam.	305 mm	12" inch.
	hole diam.	25,4 mm	1" inch.
	thickness	3,0 mm	

PACKAGING

CARTON

ORDER MULTIPLES OF



50 PCS



3 teeth-mulching purpose bent blades.

P/N	DESCRIPTION		
05001005	outside diam.	300 mm	11.8" inch.
	hole diam.	20 mm	.78"inch.
	thickness	3,0 mm	
05001006	outside diam.	300 mm	11.8" inch.
	hole diam.	25,4 mm	1" inch.
	thickness	3,0 mm	

PACKAGING

CARTON

ORDER MULTIPLES OF



40 PCS



3 teeth.

P/N	DESCRIPTION		
5001022	outside diam.	255 mm	10" inch.
	hole diam.	25,4 mm	1" inch.
	thickness	3,0 mm	
5001023	outside diam.	305 mm	12" inch.
	hole diam.	25,4 mm	1" inch.
	thickness	3,0 mm	
5001030	outside diam.	305 mm	12" inch.
	hole diam.	20 mm	.78"inch.
	thickness	3,0 mm	

PACKAGING

CARTON

ORDER MULTIPLES OF



25 PCS

Steel Blades



NEW



3 teeth.

P/N	DESCRIPTION		
05001009	outside diam.	300 mm	11.8" inch.
	hole diam.	20 mm	.78" inch.
	thickness	2,25 mm	
05001010	outside diam.	300 mm	11.8" inch.
	hole diam.	25,4 mm	1" inch.
	thickness	2,25 mm	

PACKAGING

CARTON

ORDER MULTIPLES OF



25 PCS



NEW



10 and 12 teeth.

P/N	DESCRIPTION		
05001011 10 teeth	outside diam.	255 mm	10" inch.
	hole diam.	25,4 mm	1" inch.
	thickness	2,0 mm	
05001012 12 teeth	outside diam.	255 mm	10" inch.
	hole diam.	25,4 mm	1" inch.
	thickness	2,0 mm	

PACKAGING

CARTON

ORDER MULTIPLES OF



25 PCS



20 teeth new design tooth profile blade for most efficient clearing operations reversible and thus highly cost competitive.

P/N	DESCRIPTION		
05001007	outside diam.	255 mm	10" inch.
	hole diam.	25,4 mm	1" inch.
	thickness	2,0 mm	

PACKAGING

CARTON

ORDER MULTIPLES OF



35 PCS

Steel Blades



Chisel profile tooth to be ground by means of flat file holder P/N 1012962



Chisel profile tooth to be ground by means of flat file holder P/N 1012962



22 teeth.

P/N	DESCRIPTION		
5001041	outside diam. hole diam. thickness	225 mm 20 mm 1,8 mm	8,9" inch. .78"inch.
5001042	outside diam. hole diam. thickness	225 mm 25,4 mm 1,8 mm	8,9" inch. 1" inch.

PACKAGING

NYLON BAG

ORDER MULTIPLES OF



25 PCS

22 / 24 / 26 teeth.

P/N	DESCRIPTION		
05001000 22 teeth	outside diam. hole diam. thickness	200 mm 20 mm 1,6 mm	7,9" inch. .78"inch.
05001001 22 teeth	outside diam. hole diam. thickness	200 mm 25,4 mm 1,6 mm	7,9" inch. 1" inch.
05001002 24 teeth	outside diam. hole diam. thickness	230 mm 20 mm 1,8 mm	9" inch. .78"inch.
05001003 24 teeth	outside diam. hole diam. thickness	230 mm 25,4 mm 1,8 mm	9" inch. 1" inch.
5001035 26 teeth	outside diam. hole diam. thickness	250 mm 25,4 mm 1,8 mm	9,8" inch. 1" inch.
5001036 26 teeth	outside diam. hole diam. thickness	250 mm 20 mm 1,8 mm	9,8" inch. .78"inch.

PACKAGING

NYLON BAG

ORDER MULTIPLES OF



25 PCS

60 / 80 teeth.

P/N	DESCRIPTION		
5001013 60 teeth	outside diam. hole diam. thickness	230 mm 25,4 mm 1,4 mm	9" inch. 1" inch.
5001039 60 teeth	outside diam. hole diam. thickness	230 mm 20 mm 1,4 mm	9" inch. .78"inch.
5001014 80 teeth	outside diam. hole diam. thickness	255 mm 25,4 mm 1,4 mm	10" inch. 1"inch.
5001040 80 teeth	outside diam. hole diam. thickness	255 mm 20 mm 1,4 mm	10" inch. .78"inch.

PACKAGING

NYLON BAG

ORDER MULTIPLES OF



25 PCS



Metal Net Face Shields



CE
SCREEN EN 1731-S
MUFFS EN 352-1



Professional face screen with metal net shield. Heavy duty adjustable face screen with ear muffs for professional demand. SNR: 30dB.

P/N	DESCRIPTION
-----	-------------

5120915	"Pro" face screen net shield
---------	------------------------------

SCREEN DIMENSIONS: Width: 370 mm / Height: 190 mm

PACKAGING

CARTON
(2 PCS PER BOX)

ORDER MULTIPLES OF



SPARE PARTS

1093046	SCREEN NET SHIELD
1093073	KIT SCREW AND LOCK-RING

CE
SCREEN EN 166-B
MUFFS EN 352-1



Professional face screen with polycarbonate shield. Heavy duty adjustable face screen with ear muffs for professional demand. SNR: 30dB.

P/N	DESCRIPTION
-----	-------------

5120916	"Pro" face screen polycarbonate shield
---------	--

SCREEN DIMENSIONS: Width: 450 mm / Height: 190 mm
Thickness: 0,8 + 1 mm

PACKAGING

CARTON
(2 PCS PER BOX)

ORDER MULTIPLES OF



SPARE PARTS

1093045	SCREEN POLYCARBONATE SHIELD
1093073	KIT SCREW AND LOCK-RING



Metal Net Face Shields



CE
SCREEN EN 1731-S



Heavy duty type. Adjustable, with metal net shield. Highest safety and comfort. Extra large shield.

P/N	DESCRIPTION
-----	-------------

5120912	"Pro" face screen net shield
---------	------------------------------

SCREEN DIMENSIONS: Width: 370 mm / Height: 190 mm

PACKAGING

CARTON
(12 PCS PER BOX)

ORDER MULTIPLES OF



SPARE PARTS

1093046	SCREEN NET SHIELD
1093073	KIT SCREW AND LOCK-RING

CE
SCREEN EN 166-B



Heavy duty type. Adjustable, with metal net shield. Highest safety and comfort. Extra large shield.

P/N	DESCRIPTION
-----	-------------

5120913	"Pro" face screen
---------	-------------------

SCREEN DIMENSIONS: Width: 450 mm / Height: 190 mm
Thickness: 0,8 ÷ 1 mm

PACKAGING

CARTON
(12 PCS PER BOX)

ORDER MULTIPLES OF



SPARE PARTS

1093045	SCREEN POLYCARBONATE SHIELD
1093073	KIT SCREW AND LOCK-RING

Polycarbonate Face Shields



CE
SCREEN EN 1731-S



Adjustable, with a spongy stripe. Metal net shield.

P/N	DESCRIPTION
5120901	Face screen extra-light
SCREEN DIMENSIONS: Height: 190 mm	

PACKAGING



CARTON
(8 PCS PER BOX)

ORDER MULTIPLES OF



56 PCS

CE
SCREEN EN 166-B



Adjustable, with a spongy stripe.

P/N	DESCRIPTION
5120903	Face screen
SCREEN DIMENSIONS: Height: 190 mm Thickness: 0,8 ÷ 1 mm	

PACKAGING



CARTON
(8 PCS PER BOX)

ORDER MULTIPLES OF



56 PCS

Polycarbonate Face Shields



SCREEN EN 1731-S



Adjustable, with a spongy stripe. Metal net shield.

P/N	DESCRIPTION
5120922	Face screen
SCREEN DIMENSIONS: Height: 190 mm	

PACKAGING



CARTON
(12 PCS PER BOX)

ORDER MULTIPLES OF



72 PCS



SCREEN EN 166-B



Adjustable, with a spongy stripe.

P/N	DESCRIPTION
5120921	Face screen extra-light
SCREEN DIMENSIONS: Height: 190 mm Thickness: 0,8 ÷ 1 mm	

PACKAGING



CARTON
(12 PCS PER BOX)

ORDER MULTIPLES OF



72 PCS



Ear Muffs



MUFFS EN 352-1



P/N	DESCRIPTION
5135902	CE approved ear muffs. SNR: 30 dB.
PACKAGING	ORDER MULTIPLES OF
NYLON BAG	10 PCS



MUFFS EN 352-1



P/N	DESCRIPTION
5135901	CE approved ear muffs. SNR: 27 dB.
PACKAGING	ORDER MULTIPLES OF
NYLON BAG	10 PCS

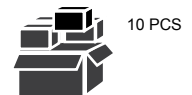

Goggles



SCREEN EN 166-B



P/N	DESCRIPTION
5130901	CE approved goggles. WITH NON FOGGING LENSES
PACKAGING	ORDER MULTIPLES OF
NYLON BAG	10 PCS



SCREEN EN 1731-3



P/N	DESCRIPTION
5130902	CE approved goggles. WITH NYLON MESH LENSES
PACKAGING	ORDER MULTIPLES OF
NYLON BAG	10 PCS



Safety Helmet

CE LOGGER'S HELMET ASSEMBLY



CE
HELMET EN 397
SCREEN EN 166 and EN 1731
MUFFS EN 352-3



For the professional users, comfortable and complete with EN approved ear and face protection sets.

- Safety helmet complies with 89/686/EEC, EN 397
- Face protection complies with EN166 and EN 1731
- Ear Muffs comply with EN 352-3



P/N	DESCRIPTION
51209001	Logger's helmet assembly

PACKAGING

CARTON

ORDER MULTIPLES OF



12 PCS



SPARE PARTS



1	S00404000	NET SHIELD SUPPORT	20 PCS
2	S00901000	SCREEN NET SHIELD	20 PCS
3	C03100000	EAR MUFFS	20 PCS

Shin Guards

FOR HOBBYISTS AND PROFESSIONALS

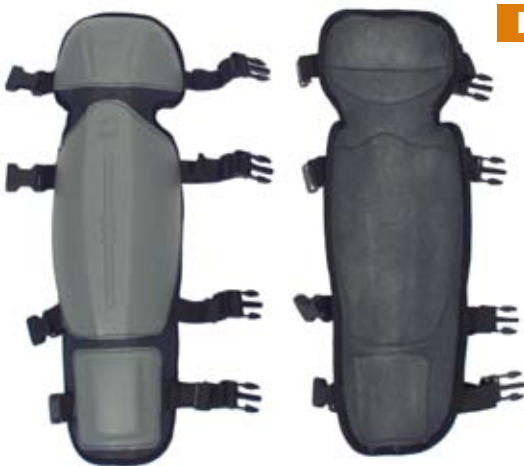

NEW

Designed to protect legs from knee down to ankle. Their components and production make them light, comfortable, easy-on, easy-off and at the same time strong and shock-resistant.

P/N	DESCRIPTION
51809000	Shin guards

PACKAGING

NYLON BAG
(2 PCS PER BAG)

ORDER MULTIPLES OF



10 PAIRS



Brushcutter Shoulder Straps



P/N	DESCRIPTION
-----	-------------

5150901	Simple and comfortable shoulder strap.
---------	--

PACKAGING	ORDER MULTIPLES OF
-----------	--------------------

NYLON BAG	 50 PCS
-----------	--



COMFORT

P/N	DESCRIPTION
-----	-------------

5150902	Simple shoulder strap with waist pad.
---------	---------------------------------------

PACKAGING	ORDER MULTIPLES OF
-----------	--------------------

NYLON BAG	 25 PCS
-----------	---

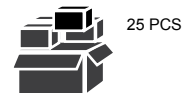

COMFORT PLUS

P/N	DESCRIPTION
-----	-------------

5150903	Double shoulder strap with waist pad. Safety quick release.
---------	---

PACKAGING	ORDER MULTIPLES OF
-----------	--------------------

NYLON BAG	 20 PCS
-----------	--



SUPER COMFORT

P/N	DESCRIPTION
-----	-------------

5150904	Super comfort strap with waist pad. Safety quick release.
---------	---

PACKAGING	ORDER MULTIPLES OF
-----------	--------------------

NYLON BAG	 5 PCS
-----------	---



Blade Guard



NEW



- Universal plastic blade guard for Nylon heads and Nylon or Steel Blades.
- Mounting kit for shaft arms Ø 24 - 26 – 28 mm included.
 - Metallic mounting clamps assure a perfect and durable fixing performance.
 - Easy and handy assembling.
 - Removable lower plastic guard allows the right blade usage.

P/N	DESCRIPTION
51109001	Cut diameter 380 mm
51109000	Cut diameter 420 mm

Universal mounting To fit shaft: Ø24mm / Ø26 mm / Ø28 mm

PACKAGING

NYLON BAG

ORDER MULTIPLES OF



40 PCS

HIGHLIGHTS



Blade guard, nylon.
To fit shaft Ø 24 - Ø 26 - Ø 28 mm Standard.

P/N	DESCRIPTION
5110901	Blade guard - nylon

PACKAGING

NYLON BAG

ORDER MULTIPLES OF



50 PCS



Blade Guard



Blade guard, metal super.
To fit shaft Ø 24 - Ø 26 - Ø 28 mm.

P/N	DESCRIPTION
5100902	Blade guard - metal super
PACKAGING	
NYLON BAG	
ORDER MULTIPLES OF	
 30 PCS	



Blade guard, metal.
With adjustable rubber protection, best performance when using the nylon heads.

P/N	DESCRIPTION
5100901	Blade guard - metal
PACKAGING	
NYLON BAG	
ORDER MULTIPLES OF	
 20 PCS	

Blade Support



Blade support, metal, fix.

P/N	DESCRIPTION
5250001	Bore 8 mm
5250002	Bore 10 mm
PACKAGING	
NYLON BAG	
ORDER MULTIPLES OF	
 10 PCS	



P/N	DESCRIPTION
5250003	Bore 12 mm
5250004	Bore 14 mm
PACKAGING	
NYLON BAG	
ORDER MULTIPLES OF	
 10 PCS	

Plastic Cans



Fuel Cans of best quality, delivered complete with flexible spout, handy and useful for professional and private users.



P/N	DESCRIPTION	PACKAGING	
1 51709001	Can L 5	nylon bag 24 PCS	240 PCS per pallet
2 51709002	Can L 10	nylon bag 14 PCS	98 PCS per pallet

SPARE PARTS

K00404001	COMPLETE SPOUT
K00404000	COMPLETE CAP

PACKAGING
NYLON BAG

ORDER MULTIPLES OF
 4 PCS

Double use plastic can, red.



P/N	DESCRIPTION
5170902	Can L 3,650 + 1,450

PACKAGING
NYLON BAG

ORDER MULTIPLES OF
 14 PCS



Plastic Cans



CERTIFIED  



Double use plastic can, red.
High quality, light and resistant.
Professional type.

P/N DESCRIPTION

5170901 Can L 5 + 2,5 - professional type

PACKAGING

CARTON

ORDER MULTIPLES OF



SPARE PARTS

- 1 **5170001** COMPLETE SPOUT
- 2 **5170003** COMPLETE CAP

PACKAGING

NYLON BAG

ORDER MULTIPLES OF



CERTIFIED  



Double use plastic can, white.
High quality, light and resistant.

P/N DESCRIPTION

5170903 Can L 5 + 2,5 - professional type

PACKAGING

CARTON

ORDER MULTIPLES OF



SPARE PARTS

- 1 **5170001** COMPLETE SPOUT
- 2 **5170003** COMPLETE CAP

PACKAGING

NYLON BAG

ORDER MULTIPLES OF



EASYFill

funnel self-closing spout



NEW



Spout for cans with blocking system in the case of fuel leakage.
- Easy to fit on Tecomec cans.
- Guarantees correct filling without liquid spillage.
- Suitable for all tanks used by major manufacturers of gardening machinery.

P/N	DESCRIPTION
5170905	Funnel self-closing spout

PACKAGING
NYLON BAG

ORDER MULTIPLES OF
 20 PCS

HIGHLIGHTS



> Suitable for use on Tecomec dual-purpose cans: P/N 5170901, P/N 5170902 and P/N 5170903.



> End pull-out part. When pulled out, the liquid flows out; when it is in the normal position, the liquid does not flow out.



> The cap can also be put at the top to protect it against impact and dirt.

Funnel Assy Filter



P/N	DESCRIPTION
1 5175901	Funnel assy - small
2 5175902	Funnel assy - medium
3 5175001	Funnel filter

PACKAGING
CARTON

ORDER MULTIPLES OF
 24 PCS



Grease Stickers

for bevel gear pairs



Grease for bevel gear.

P/N	DESCRIPTION
5160001	Grease stickers

PACKAGING

CARTON

ORDER MULTIPLES OF



24 PCS



chain saw spare parts



SparkPlugs	3
IgnitionCoils	3
Condensers	3
PointSets	4
ElectricalAccessories	4
FuelFilters	5
AirFilters	6
AirFilters	7
AirFilters	8
AirFilters	9
FuelCaps	9
OilCaps	9
VibrationDampings	10
Pawls	10
MetalRings - PlasticRings	10
Pulleys	10
StarterRope	11
StarterHandles	11
StarterHandles	12
CylindersAssy - PistonsAssy - PistonRings	13
CylindersAssy - PistonsAssy - PistonRings	14
CylindersAssy - PistonsAssy - PistonRings	15
CylindersAssy - PistonsAssy - PistonRings	16
Cranks Shaft	17
Pin Sets	17
Gasket Sets	17
Chain Tightener Assemblies	18
Chain Handles	18
Nuts	18
CombinationWrenches	19
CombinationWrenches	20

PROVIS.

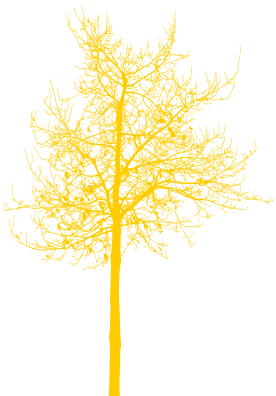



**chain
saw
spare parts**

Forestry and gardening accessories



Spark Plugs

SUITABLE FOR THE FOLLOWING CHAIN SAWS/ENGINES



ORDER MULTIPLES OF
10 PCS



ENGINE	OUR REF.	HEXAGON	BOSCH	OUR REF. CHAMPION	NGK
CHAIN SAW BRUSH-CUTTERS	501157	19	WS7F	CJ7Y	BPM7A
CHAIN SAW	501159	19	WS7F	CJ8	BM6A
CHAIN SAW	501160	19	WKA200TRS	RCJ8Y	BPMR6A
CHAIN SAW	501161	19	WRS5F	RCJ7Y	BPMR7A
LAWN-MOWER	501158	21	W9ECO	J17LM	B4LM
HONDA	501162	21	WR6DC	RN10X	BPR6ES
HONDA	501163	21	WR6DCX	RN10Y4	BPR6ES-11

Ignition Coils

SUITABLE FOR THE FOLLOWING CHAIN SAWS



ENGINE	MODEL	OUR REF. T. MEC	DUCATI
HUSQVARNA	45 - 51 - 55 - 61 - 254 - 257 - 262 - 268 - 272 - 394 - 250RX - 250R - 245R - 240R	502185*	
STIHL	021 - 023 041 - 045 038 MAGNUM 051		502169* 502901 502183* 502184*

* ELECTRONIC IGNITION

Condensers

SUITABLE FOR THE FOLLOWING CHAIN SAWS



ORDER MULTIPLES OF
5 PCS



MAKE	MODEL	HEXAGON
DOLMAR	117 - 118 - 122 - 144 - 152	503126
HUSQVARNA	65 - 77 - 160 - 163 - 180 - 380	503126
PARTNER	R11 - R12 - R14 - R16	503126
STIHL	08 - 041 - 045 - 051 - 075	503126



Point Sets

SUITABLE FOR THE FOLLOWING CHAIN SAWS



ORDER MULTIPLES OF
5 PCS



MAKE	MODEL	OUR. REF.
DOLMAR	CA - 117 - 118 - 122 (NEW)	504135
HUSQVARNA	65 - 77 - 180 - 380 (NEW)	504135
STIHL	08 - 041 - 045 - 051 - 075 (NEW)	504135

Electrical Accessories

SUITABLE FOR THE FOLLOWING CHAIN SAWS



ORDER MULTIPLES OF
10 PCS



SPARK PLUG TERMINAL WITH SPRING	OUR. REF.
5 mm WIRE	506102
7 mm WIRE	506101
SPRING ONLY	506103

ORDER MULTIPLES OF
10 PCS



SPARK PLUG TERMINAL WITH SPRING	OUR. REF.
STANDARD TYPE	506107

ORDER MULTIPLES OF
10 PCS



SWITCH	OUR. REF.
UNIVERSAL TYPE	506110
HUSQUARNA 61 - 266 - 281 - 288	506163
O.E.M. Part. No. 501 52 66 - 02	



RUBBER INSULATED CABLE FOR HIGH TEMPERATURES, FROM -20° ÷ +100°C	OUR. REF.
Ø 5 mm x 1 m	506142
Ø 7 mm x 1 m	506143
10 m PER REEL - THE PRICE IS PER 1 m	

INSULATED CABLE STANDARD	OUR. REF.
Ø 5 mm x 1 m	506111
Ø 7 mm x 1 m	506112
10 m PER REEL - THE PRICE IS PER 1 m	

Fuel Filters

SUITABLE FOR THE FOLLOWING CHAIN SAWS



ORDER MULTIPLES OF
10 PCS



FUEL FILTER "POREX" (HU TYPE)

OUR. REF.

Small "POREX"

524103

POREX replacement element only

524104

ORDER MULTIPLES OF
10 PCS



FUEL FILTER ASSY (HU TYPE)

OUR. REF.

Small FELT

524901

FELT only

524900

ORDER MULTIPLES OF
10 PCS



FUEL FILTER ASSY (HS TYPE)

OUR. REF.

Large FELT

524101

FELT only

524102

ORDER MULTIPLES OF
10 PCS



SUPER TYPE - WITH INSIDE SINTERED ELEMENT OUR. REF.

FUEL FILTER ASSY (standard fitting)

524123

FUEL FILTER ASSY (suitable for stihl)

524133

ORDER MULTIPLES OF
10 PCS



FUEL FILTERS "POREX"

OUR. REF.

Ø 5 mm (suitable for HUSQVARNA)

524148

Ø 5,7 mm (suitable for TILLOTSON)

524154

Ø 8,5 mm (suitable for STIHL)

524155



RUBBER FUEL LINE

OUR. REF.

inside Ø 3,2 mm

524106

inside Ø 4,5 mm

524107

5 m PER REEL - THE PRICE IS PER 1m

Air Filters

SUITABLE FOR THE FOLLOWING CHAIN SAWS



ORDER MULTIPLES OF

5 PCS

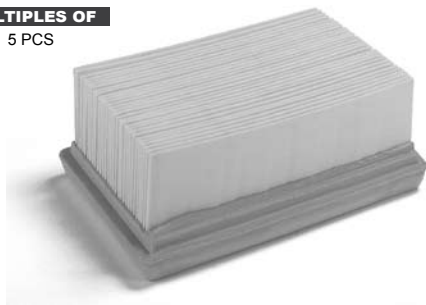

DOLMAR

OUR. REF.

PC6212 - PC6214 (Cutquicks)

540355

O.E.M. part No. 394 173 010

ORDER MULTIPLES OF

5 PCS



HUSQVARNA

OUR. REF.

238-242

540275

O.E.M. part No. 503 15 19 03

ORDER MULTIPLES OF

5 PCS



HUSQVARNA

OUR. REF.

61 - 66 - 266 - 281 - 288

540173

O.E.M. part No. 501 80 71 01

ORDER MULTIPLES OF

5 PCS



PARTNER

OUR. REF.

R16 - S50 - S55 - P55 - P70

540127

O.E.M. part No. 315475

ORDER MULTIPLES OF

5 PCS



PARTNER

OUR. REF.

K650 (Pre-filter)

540273

O.E.M. part No. 505 315 545

Air Filters

SUITABLE FOR THE FOLLOWING CHAIN SAWS



ORDER MULTIPLES OF

5 PCS



STIHL

OUR. REF.

028

540166

O.E.M. part No. 1118 120 1610

ORDER MULTIPLES OF

5 PCS



STIHL

OUR. REF.

038 - 038 Magnum

540172

O.E.M. part No. 1119 120 1610

ORDER MULTIPLES OF

5 PCS

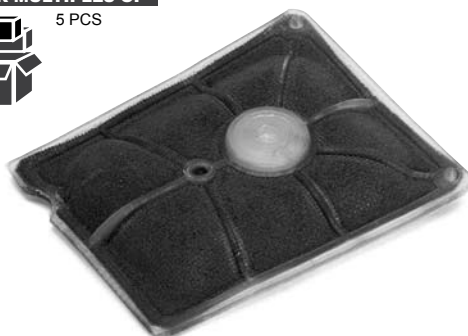

STIHL

OUR. REF.

051

540136

O.E.M. part No. 1111 120 1601

ORDER MULTIPLES OF

5 PCS

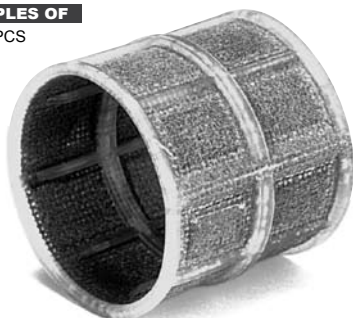

STIHL

OUR. REF.

08

540134

O.E.M. part No. 1108 120 1600



Air Filters

SUITABLE FOR THE FOLLOWING CHAIN SAWS



ORDER MULTIPLES OF

5 PCS



STIHL

OUR. REF.

TS 350-510

540133

O.E.M. part No. 4201 140 1801

ORDER MULTIPLES OF

5 PCS



STIHL

OUR. REF.

TS 360

540174

O.E.M. part No. 4201 140 1802

ORDER MULTIPLES OF

5 PCS



STIHL

OUR. REF.

TS 350 - 360 - 510 (Pre filter)

540238

O.E.M. part No. 4201 141 0310

ORDER MULTIPLES OF

5 PCS



STIHL

OUR. REF.

TS 400

540332

O.E.M. part No. 4223 140 0300

Air Filters

SUITABLE FOR THE FOLLOWING CHAIN SAWS



ORDER MULTIPLES OF
5 PCS

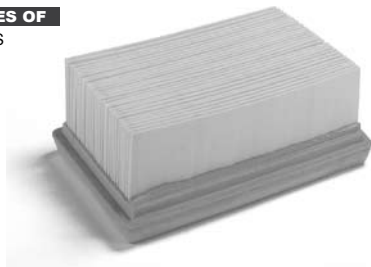

STIHL	OUR. REF.
TS 400	540336
O.E.M. part No. 4223 141 0300	

ORDER MULTIPLES OF
5 PCS



STIHL	OUR. REF.
TS 400	540337
O.E.M. part No. 4223 141 0600	

Fuel Caps

SUITABLE FOR THE FOLLOWING CHAIN SAWS



ORDER MULTIPLES OF
10 PCS



MAKE	MODEL	OUR REF.	O.E.M. PART NO.
HUSQVARNA	36 - 41 - 42 - 50 - 55 - 154 - 254 262 - 281 - 288 - 394 - 3120 234 - 238	550151	501 81 96 02
	65 - 77 (New) - 380 - 480	551107	501 56 45-01
	61 - 66 - 266 - 268 - 272 - 2101 181	550151	501 81 96-01
JONSERED	625 - 630 - 631 - 670	551107	5015 645-01
STIHL	044 024 - 028 - 034 - 038 - 042 - 048	550145	1117 350 0500
	08	550121	1107 350 0500

Oil Caps

SUITABLE FOR THE FOLLOWING CHAIN SAWS



ORDER MULTIPLES OF
10 PCS



MAKE	MODEL	OUR REF.	O.E.M. PART NO.
HUSQVARNA	36-41-50-51-55-154-254-262 234-238	551153	501 76 56 02
	281 - 288 - 394	551145	501 62 66-01
	42-61-66-242-266-268-272 181	550151	501 81 96 02
	044	551145	501 62 66 02
STIHL	024 - 028 - 034 - 038 - 042 - 048	550145	1117 350 0500
	064 - 084	551149	1117 640 3600
	032	550145	1107 350 0500
		551149	1117 640 3600

Vibration Dampings

SUITABLE FOR THE FOLLOWING CHAIN SAWS



ORDER MULTIPLES OF
10 PCS



MAKE	MODEL	OUR REF.	O.E.M. PART NO.
HUSQVARNA	480 - 61 - 162 Metal Crankcase	657122	50 12 763-01
	61 - 162 Metal Crankcase	657123	50 15 305-01
	266 Plastic Crankcase	657132	501 69 94-01
	266 Plastic Crankcase	657133	501 62 87-01
STIHL	028 - 038 Series	657134	1118 790 9930
	038 Series	657135	1121 790 9912
	028 - 038 Series	657136	1121 790 9909
	051 AV BACK HANDLE	657140	1111 790 9900
	051 AV FRONT HANDLE (DOWN)	657141	1111 790 9915
	051 AV FRONT HANDLE (UP)	657142	1111 790 9905

Pawls

SUITABLE FOR THE FOLLOWING CHAIN SAWS



ORDER MULTIPLES OF
10 PCS



MAKE	MODEL	OUR REF.	O.E.M. PART NO.
STIHL	009-010-011-024-028 (Old Mod.)-032	560111	1118 195 7200
	08-038-042-048-051-056 (Old Mod.)	560170	1117 195 7200
	Pawl Spring	560179	1117 195 7200
	08-038-051-056-064-066-076-084-TS360	560202	1124 195 7200
	009-010-011-012-021-023-024-025-026-028-034-036-044	560203	1125 195 7200

Metal Rings - Plastic Rings

SUITABLE FOR THE FOLLOWING CHAIN SAWS



ORDER MULTIPLES OF
10 PCS



MAKE	MODEL	DESCRIPTION	OUR REF.	O.E.M. PART NO.
STIHL	08-041-045	Metal ring	560115	0000 961 5115
	050-051	Metal ring	560117	1111 195 4100
	08-041-045	Plastic ring	560116	0000 961 5116

Pulleys

SUITABLE FOR THE FOLLOWING CHAIN SAWS



ORDER MULTIPLES OF
5 PCS



MAKE	MODEL	OUR REF.	O.E.M. PART NO.
HUSQVARNA	266 - 66 - 181 (Bore Ø 10)	560182	501 52 07-01
	266 - 66 - 181 (Bore Ø 14)	560211	503 10 24-02
	268 - 272 (Bore Ø 14 Hub Long)	560253	503 10 24 03
STIHL	036 - 044	560237	1128 195 0400
	08	560146	1107 190 1000
	038-041-042-045-048-051-056	560224	1117 195 0402
	08-075-TS350 (Metal)		
	034 - 024 (Nylon)	560201	1125 195 0401
	08 - 051 - 064 - 066 (Nylon)	560200	1122 195 0400

Starter Rope

SUITABLE FOR THE FOLLOWING CHAIN SAWS



DESCRIPTION

OUR. REF.

Spool Ø 3,0 mm x 100 m
Spool Ø 3,5 mm x 100 m
Spool Ø 4,0 mm x 100 m
Spool Ø 4,5 mm x 100 m

560125
560126
560127
560128

THE PRICE IS PER 100 m SPOOL

Starter Handles

SUITABLE FOR THE FOLLOWING CHAIN SAWS



ORDER MULTIPLES OF

10 PCS



STIHL

OUR. REF.

010 - 015 - 020 - 028 - 031 - 032 (Old Mod.)

560119

ORDER MULTIPLES OF

10 PCS



STIHL

OUR. REF.

08 - 038 - 041 - 042 - 048 - 051 - 056 - 070 - 075 (Old Mod.)

560118

ORDER MULTIPLES OF

10 PCS



STIHL

OUR. REF.

Standard (NEW)

560213

O.E.M. part No. 1121 195 3400

Starter Handles

SUITABLE FOR THE FOLLOWING CHAIN SAWS



ORDER MULTIPLES OF

10 PCS



HUSQVARNA

OUR REF.

Standard

560191

O.E.M. part No. 501 55 14-02

ORDER MULTIPLES OF

10 PCS



STANDARD TYPE - SMALL

OUR REF.

560121

ORDER MULTIPLES OF

10 PCS



STANDARD TYPE - MEDIUM

OUR REF.

560120

ORDER MULTIPLES OF

10 PCS



**STANDARD TYPE - LARGE
COMPLETE WITH PLASTIC CAP**

OUR REF.

560123

Cylinders Assy - Pistons Assy Piston Rings

SUITABLE FOR THE FOLLOWING CHAIN SAWS



ORDER MULTIPLES OF
10 PCS



MAKE	DESCRIPTION	SEL.	OUR REF.	O.E.M. PART NO.
DOLMAR	Cylinder assy Ø 47 mm		570258	123 130 200
309 (NEW)	Piston ring		574119	123 132 020

ORDER MULTIPLES OF
10 PCS



MAKE	DESCRIPTION	SEL.	OUR REF.	O.E.M. PART NO.
HUSQVARNA	Cylinder assy Ø 42 mm	B	570254	503 53 68-02
242-242XP	Piston ring		574159	503 28 90-05

ORDER MULTIPLES OF
10 PCS



MAKE	DESCRIPTION	SEL.	OUR REF.	O.E.M. PART NO.
HUSQVARNA	Cylinder assy Ø 45 mm	B	570264	503 50 39-02
254-254XP	Piston assy		572507	503 50 37-01
	Piston ring		574161	503 28 90-11

ORDER MULTIPLES OF
10 PCS



MAKE	DESCRIPTION	SEL.	OUR REF.	O.E.M. PART NO.
HUSQVARNA	Cylinder assy Ø 48 mm	B	570252	503 53 20-71
61	Piston assy		572499	503 53 90-02
	Piston ring		574157	503 28 90-15



Cylinders Assy - Pistons Assy Piston Rings

SUITABLE FOR THE FOLLOWING CHAIN SAWS

ORDER MULTIPLES OF

10 PCS



MAKE	DESCRIPTION	SEL.	OUR REF.	O.E.M. PART NO.
HUSQVARNA	Cylinder assy Ø 50 mm		570280	501 65 85 71
268-268S	Piston assy	B	572524	501 65 94 03
268K	Piston ring		574142	503 28 90 17

ORDER MULTIPLES OF

10 PCS



MAKE	DESCRIPTION	SEL.	OUR REF.	O.E.M. PART NO.
HUSQVARNA	Cylinder assy Ø 48 mm		570282	5014 178-01
65-265	Piston assy	B	572526	5012 056-03
	Piston ring		574157	5012 059-02

ORDER MULTIPLES OF

10 PCS



MAKE	DESCRIPTION	SEL.	OUR REF.	O.E.M. PART NO.
	Cylinder assy Ø 50 mm		570268	506 09 92-12
PARTNER	Piston assy	B	572511	506 09 90-03
K650 ACTIVE	Piston ring		574137	503 28 90-17
	De-Compression Valve		576118	503 71 33-01

ORDER MULTIPLES OF

10 PCS



MAKE	DESCRIPTION	SEL.	OUR REF.	O.E.M. PART NO.
STHIL	Cylinder assy Ø 44 mm		570281	1121 020 1208
026	Piston assy	B	572525	1121 030 2001
	Piston ring		574170	1121 034 3010

Cylinders Assy - Pistons Assy - Piston Rings

SUITABLE FOR THE FOLLOWING CHAIN SAWS



ORDER MULTIPLES OF

10 PCS



MAKE	DESCRIPTION	SEL.	OUR REF.	O.E.M. PART NO.
STIHL 028 SUPER	Cylinder assy Ø 46 mm	B	570216	1118 020 1202
	Piston assy		572449	1118 030 2003
	Piston ring		574144	1118 034 3001

ORDER MULTIPLES OF

10 PCS



MAKE	DESCRIPTION	SEL.	OUR REF.	O.E.M. PART NO.
STIHL 034-036	Cylinder assy Ø 48 mm	B	570250	1125 020 1213
	Piston assy		572497	1125 030 2001
	Piston ring		574158	1125 034 3001

ORDER MULTIPLES OF

10 PCS



MAKE	DESCRIPTION	SEL.	OUR REF.	O.E.M. PART NO.
STIHL 038 MAGNUM	Cylinder assy Ø 52 mm	B	570272	1119 020 1202
	Piston assy		572515	1119 030 2002
	Piston ring		574106	1115 034 3010

ORDER MULTIPLES OF

10 PCS



MAKE	DESCRIPTION	SEL.	OUR REF.	O.E.M. PART NO.
STIHL 051- TS510	Cylinder assy Ø 52 mm	B	570162	1111 020 1200
	Piston assy		572261	1111 030 2000
	Piston ring		574106	1115 034 3001



Cylinders Assy - Pistons Assy - Piston Rings

SUITABLE FOR THE FOLLOWING CHAIN SAWS



ORDER MULTIPLES OF

10 PCS



MAKE	DESCRIPTION	SEL.	OUR REF.	O.E.M. PART NO.
STIHL 08-TS350	Cylinder assy Ø 47 mm	B	570155	1108 020 1220
	Piston assy		572247	1108 030 2020
	Piston ring		574119	1108 034 3001

ORDER MULTIPLES OF

10 PCS



MAKE	DESCRIPTION	SEL.	OUR REF.	O.E.M. PART NO.
STIHL 08S-TS360	Cylinder assy Ø 49 mm	B	570227	4201 020 1200
	Piston assy		572460	4201 030 2000
	Piston ring		574143	4201 034 3000

ORDER MULTIPLES OF

10 PCS



MAKE	DESCRIPTION	SEL.	OUR REF.	O.E.M. PART NO.
STIHL TS400	Cylinder assy Ø 49 mm	B	570277	4223 020 1200
	Piston assy		572521	4223 030 2000
	Piston ring		574143	1127 034 3006

Crankshaft

SUITABLE FOR THE FOLLOWING CHAIN SAWS



MAKE	MODEL	OUR REF.	O.E.M. PART NO.
DOLMAR	123 - 309	590143	123 120 002
HUSQVARNA	61- 268 - 272 (AFTER 93)	590165	503 61 33-71
PARTNER	K650 ACTIVE (NEW)	590200	503 15 80 01
STIHL	051 - 075	590119	1111 030 0402
	038 - 038 Super - 038 Magnum	590150	1119 030 0400
	08 - TS350 - TS360	590116	1108 030 042
	TS400	590156	4223 030 0400

Exhausts

SUITABLE FOR THE FOLLOWING CHAIN SAWS



MAKE	MODEL	OUR REF.	O.E.M. PART NO.
HUSQVARNA	266A	610140	501 65 76-01
STIHL	038 - 038S	610139	1119 140 0600

Gasket Sets

SUITABLE FOR THE FOLLOWING CHAIN SAWS



MAKE	MODEL	OUR REF. COMP. SET
HUSQVARNA	61 - 162 - 266 - 268	640145A
PARTNER	K650 ACTIVE	640182
STIHL	034 - 036	640158A
	08 - TS350	640131A
	051	640136A
	026 - 024	640180A
	TS400	640181A

Nuts

SUITABLE FOR THE FOLLOWING CHAIN SAWS

ORDER MULTIPLES OF
10 PCS



MAKE	MODEL	BAR	OUR REF. SPROCKET FLYWHEEL
STIHL	010-015- 031-032-041	670101	672110
	028 (OLD)-020	670101	
	042-045	670101	
	050-051-075	670113	671102
	056	670101	
	08	670113	
	024-028-038-044	670114	672110

Chain Tightener Assemblies

SUITABLE FOR THE FOLLOWING CHAIN SAWS



ORDER MULTIPLES OF
10 PCS



MAKE	MODEL	OUR REF.	O.E.M. PART NO.
HUSQVARNA	51-61-66-162-181-266-268 272-281-288	651172	501 53 71 01
	42-44-50-51-55 238-242-444	651173	501 81 92 01
	154-254-262	651192	501 53 71 01
JONSERED	629-630-670	651172	501 53 71 01
STIHL	08-051-075	651157	0000 951 2911 1106 644 1500

Tube Handles

SUITABLE FOR THE FOLLOWING CHAIN SAWS



MAKE	MODEL	OUR REF.	O.E.M. PART NO.
HUSQVARNA	61-66-266-268-272	654138	501 53 45-03
	50 SPECIAL -51-55-254	654151	501 87 29 07

Sprocket Rim



ORDER MULTIPLES OF
10 PCS



SPROCKET RIM			OUR REF.
SPLINE	PITCH	TEETH	
STANDARD 7	.404"	7	A0000009
SMALL 7	3/8"	7	A0000012
STANDARD 7	3/8"	7	A0000013
STANDARD 7	3/8"	8	A0000014

Combination Wrenches

SUITABLE FOR THE FOLLOWING CHAIN SAWS

Q.TY PER CARTON:

100 PIECES

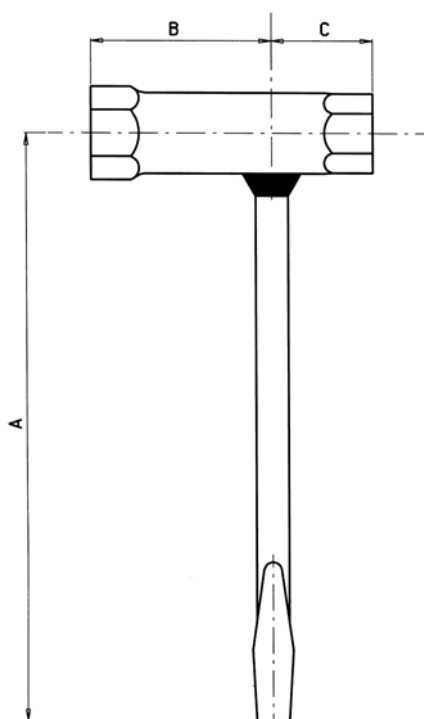

			DIMENSION (MM)				
		MODEL	A	B	C	BAR	PLUG
ALPINA	2304023	A40-C40-CP45-A70-C70	150	52	33	13	19
CASTOR	2304084	490-C90	150	34	34	17	19
	2304014	CA-CC-CT	182	35	35	17	21
DOLMAR	2304084	122-123-144-152-153 133-166-309-310-311	150	34	34	17	19
	2304080	112-113-114-116-117-119 120-120 super	150	25	25	13	19
ECHO	2304023	CS60-100-452-500-601-605 650-701-750-801-802	150	52	33	13	19
	2304077	280-302-304-315-351-400	145	60	30	10	19
	2304020	XL Serie (1° mod.)-925	150	55	25	16	19
HOMELITE	2304017	Mini	150	45	25	13	16
	2304027	XL Super VI-XL2	150	90	25	11	16
HUSQVARNA	2304023	65-77 (2° mod.) 140-160 162-180-285-2100	150	52	33	13	19
	2304025	Husky	145	42	23	11	19
	2304080	61-154-181-234-266-44 444	150	25	25	13	19
JONSERED	2304080	625-630-670	150	25	25	13	19
MC CULLOCH	2304017	Standard	150	45	25	13	16
	2304027	Mac 6	150	90	25	11	16
OLEO MAC	2304077	E140-E160-E1500-E1700 E1900-233-240-935X- 935DX	145	60	30	10	19
	2304023	254-350-355-592-930-931 938-941-942-945-946-947 950-951-956-962-970-971 980-981	150	52	33	13	19
	2304084	271-272-481-482-999	150	34	34	17	19
PARTNER	2304025	330-340	145	42	23	11	19
	2304023	R16-R17-R18-S50-S55 P55-P70-P100	150	52	33	13	19
	2304025	P12	145	42	23	11	19
PIONEER	2304023	P20-P21-P25-P26-P28-P40 P50-1200-1074-C55	150	52	33	13	19
	2304084	P41-P51 Farmsaw-P60	150	34	34	17	19
POULAN	2304024	200-300-400	150	54	24	14	19
QUADRA	2304025	Frontier	145	42	23	11	19
SOLO	2304014	50-70-125	172	35	35	17	21
	2304023	610-620-640-650	150	52	33	13	19
	2304010	010-015-020-028-031 032-041	170	50	18	13	19
STIHL	2304008	010-015-020-028-031 032-041	170	21	34	13	19
	2304084	045-050-051-070-075	150	34	34	17	19
	2304014	08	182	35	35	17	21
	2304068	Standard-New	180	40	15		19

Combination Wrenches

SUITABLE FOR THE FOLLOWING CHAIN SAWS



Q.TY PER CARTON:
100 PIECES



MAKE **OUR REF.**

STIHL **2304072** Wrench for Stihl screws (TORX 27)

Q.TY PER CARTON:
100 PIECES



MAKE **OUR REF.**

STIHL **2304074** Allen wrench for Stihl screws (TORX 27)

Q.TY PER CARTON:
100 PIECES



MAKE **OUR REF.**

ASPERA	2304083	21 x 19 x \varnothing 11 Square-Aspera and Tecumsen
BRIGGS & STRATTON	2304082	24 x 19 x \varnothing 11 Square-Briggs & Stratton (box 60 pcs)
	2304076	21 x 19 x \varnothing 3/8 Square-Briggs & Stratton Sprint

NOTE:
